

# SUBMISSION



M Fajar Wicaksono <mfajarw@email.unikom.ac.id>

---

## [IJASEIT] Submission Acknowledgement

1 message

---

IJASEIT <ijaseit@gmail.com>

Tue, Dec 8, 2020 at 5:24 PM

To: "Mr. Mochamad Fajar Wicaksono" <mfajarw@email.unikom.ac.id>

Mr. Mochamad Fajar Wicaksono:

Thank you for submitting the manuscript, "IoT Implementation for Server Room Security Monitoring Using Telegram API" to International Journal on Advanced Science, Engineering and Information Technology. With the online journal management system that we are using, you will be able to track its progress through the editorial process by logging in to the journal web site:

Manuscript URL:

<http://www.insightsociety.org/ojaseit/index.php/ijaseit/author/submission/13922>

Username: mfajarw

If you have any questions, please contact me. Thank you for considering this journal as a venue for your work.

IJASEIT

International Journal on Advanced Science, Engineering and Information Technology

---

International Journal on Advanced Science, Engineering and Information Technology

<http://insightsociety.org/ijaseit/index.php/ijaseit>

Leave this box blank  
Please submit online <http://www.insightsociety.org/ojaseit/index.php/ijaseit> in DOC file  
Editor will not receive submission by email  
**Please be sure to check for spelling and grammar before submitting your paper.**

# IoT Implementation for Server Room Security Monitoring Using Telegram API

M. F. Wicaksono\*, M. D. Rahmatya#, Ilham ^

*\*Program Studi Teknik Komputer, Universitas Komputer Indonesia, Jl. Dipati Ukur 112-116 Bandung, Indonesia  
E-mail: mfajarw@email.unikom.ac.id*

*#Program Studi Manajemen Informatika, Universitas Komputer Indonesia, Jl. Dipati Ukur 112-116 Bandung, Indonesia  
E-mail: myrna@email.unikom.ac.id*

*^Program Studi Sistem Komputer, Universitas Komputer Indonesia, Jl. Dipati Ukur 112-116 Bandung, Indonesia  
E-mail: ilham.ilhamx1997@gmail.com*

---

**Abstract**— The purpose of this research is to create a system that can monitor server room security by utilizing IoT technology, controllers, sensors, actuators, and Telegram API. The system made includes security for the indoor and outdoor parts. The method used in this study is experimental. The output obtained by the user is telegram text messages, photos, and video. The main controller on this system is the Raspberry Pi. Raspberry Pi will read input from ultrasonic sensors, PIR sensors, DHT11 sensors, and cameras. If the door is forcibly opened, the distance the ultrasonic sensor reads will get smaller, so the Raspberry Pi will activate the buzzer and send a telegram message to the user regarding the incident. The PIR sensor is here used to detect human presence in the server room. DHT11 sensor is used to measure the temperature of the server room. If the temperature is outside the threshold, the user will get a message related to it. On the outside, there is an RFID reader and keypad. This is related to access rights to the server room. If the password or RFID tag is recognized, the Raspberry Pi will deactivate the solenoid door lock. Users can ask the tool to record a video of the room conditions and also messages related to room temperature through commands sent via Telegram messages. Based on the test results using 3 test scenarios, the system has been running well where the success percentage is 100%.

**Keywords**— IoT, Server Room, Monitoring, Raspberry Pi, Telegram

---

## I. INTRODUCTION

Companies or institutions that have implemented information technology usually have server rooms. The server room is a place where important data is located. Therefore, the room must always be monitored [1]. Server room security is closely related to computer network security. This computer network security includes the use of network management and technical actions aimed at controlling and ensuring availability, data privacy, and integrity. The things above are usually categorized into two parts, namely physical security, and logical security. Physical security includes computer equipment and other facilities that must be protected from theft, human error, and damage [2]. Related to this security there is something called the defensive mechanism. These mechanisms are actions, activities, and strategies undertaken to prevent damage that can occur, reduce risks, find the causes of damage, and take appropriate steps to overcome them[3]. Physical defense mechanisms are needed to ensure the security of the

computer system environment, room selection, and computer room security [2]. Server rooms can be monitored remotely by implementing the Internet of Things (IoT). By using IoT, the condition of the server room can be monitored remotely by using a tool. The installed tool will send data related to the condition of the server room without human-computer interaction or human-human interaction [4]. The temperature and humidity in the server room are one of the important things to monitor. In Indonesia, there are already standards related to temperature and humidity set by the government in 2017. The standard temperature is in the range of 21<sup>o</sup>C-23<sup>o</sup>C and humidity is in the range of 45% to 60%. High humidity can cause corrosion and short circuits [5]. Apart from temperature and humidity, there are many other things related to server room security that must be monitored, mainly related to defense mechanisms.

A lot of research is related to this server room both for monitoring and for security. In 2016 there was already a study that discussed temperature and humidity control for server rooms. This study just focused on temperature and

humidity [6]. In the same year, other research was also conducted in this regard. The research focuses on room temperature only [7]. Other research in 2016 still focuses on temperature and humidity but there is an addition, namely the existence of an early warning sent to the user's e-mail. However, the email feature is less effective because in general, users don't open email all the time, either on their smartphone or on their computer [8]. Research in 2017 is also still focused on the problem of temperature and humidity and no features related to warnings messages are given to users [9]. A study in 2017 has added fuzzy logic to design intelligent air conditioner. However, it just focuses on temperature [10]. Other research that has been carried out in 2018 is also still focused on the problem of temperature and humidity coupled with fuzzy logic. However, in this study, there were no features related to monitoring the state of the room regarding access rights, no features for sending images and videos [4]. Furthermore, in the same year, namely 2018, there was research on this server room. However, this research only focuses on the security of the server room door by using an application and a door lock [11]. In 2019 there was new research related to this server room which was able to send notification messages via the Telegram application. However, these studies only focus on temperature and humidity [12].

Nearly all of the previous studies focused on one part of server room temperature and humidity and one that focused solely on server room entrances. So, in general, no one directly discusses monitoring the conditions and security of the server room. In this research, a system will be made to monitor the condition and security of the server room. The security scope of this research is the outside of the server room and the inside of the server room. The output that the user will get is telegram text messages and video telegrams. The main controller on this system is the Raspberry Pi. Raspberry Pi will read input from ultrasonic sensors, PIR sensors, DHT11 sensors, and cameras. The PIR sensor is here used to detect human presence in the server room. In this study, two PIR sensors were used which were placed across from each other inside the server room. DHT11 sensor is used to measure the temperature of the server room. If the temperature is outside the threshold, the user will get a message related to this and the buzzer in the room will also be active. On the outside, placed the RFID reader and keypad. This is related to access rights to the server room. If the password is entered or the RFID tag is recognized, the Raspberry Pi will deactivate the solenoid door lock to open the door and turn off the ultrasonic sensor and all PIR sensors. Users can ask the device to record a video of the room conditions and also messages related to room temperature through commands sent via Telegram messages. If there is an incident, for example, the door is forcibly opened, the distance the ultrasonic sensor reads will get smaller, so the Raspberry Pi will activate the buzzer and send a telegram message to the user regarding the incident. Then Raspberry will wait for the next command. The next action is obtained from the telegram message sent by the user. This can be a request for a video recording related to the current condition or a photo taken at that time.

## II. MATERIALS AND METHODS

As mentioned above, IoT technology can be implemented and utilized to monitor the condition of a room from afar, especially in this case, the server room. This research used an experimental method. In the implementation process, a series of experiments were carried out in this method. In this study, the Raspberry Pi 3B is used as the main brain of the system which will process all input and output. Raspberry Pi 3B is a mini PC equipped with various peripheral ports and I/O pins. Python language is used to create programs on the Raspberry Pi [13]. The input part of this system includes a DHT11 sensor, two PIR sensors, an ultrasonic sensor, an RFID reader, a keypad, and a camera module. On the other hand, the output includes Buzzer, 16x2 LCD, Relay, and Solenoid Door Lock. This telegram messaging application functions as input and output on this system. The block diagram of this system is shown in figure 1.

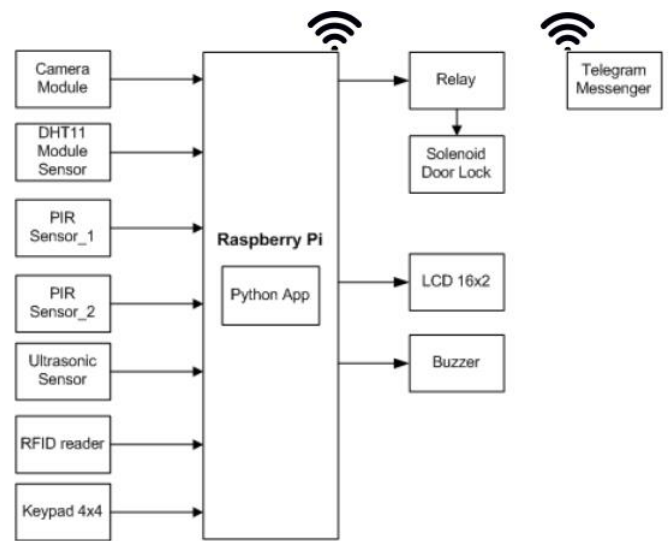

Fig. 1 System Block Diagram IoT Implementation for Server Room Security Monitoring Using Telegram API

DHT11 is a sensor module that can be used to measure temperature and humidity [14]. In this study, DHT11 is placed in the server room and data from DHT11 will be read by Raspberry Pi. The PIR sensor can be used to detect human movement [15]. This study uses the PIR HC-SR501 sensor module. This sensor module has a detection angle of 120° and a maximum detection distance of 7 meters [16]. The delay in this module can be adjusted from 2 seconds to 4 seconds [17]. In this study, two HC-SR501 sensors were used. The two sensors are placed opposite in the server room. In this case, it is intended to detect intruders who enter the server room via the roof. Ultrasonic sensors are commonly used to measure distances. In this study, the HC-SR04 ultrasonic sensor was used. This sensor can measure distances with a range of 2cm-400cm. [18]. In this study, the HC-SR04 ultrasonic sensor was placed on the wall in the room near the entrance. The sensor will send a legible distance to the Raspberry Pi. If there are thieves who try to enter by breaking the entrance, the incident will be immediately known because the distance read by the ultrasonic sensor is outside the range specified in the program. Furthermore, the Raspberry Pi will activate the

buzzer and send a message to the user regarding the incident. A special camera module for the Raspberry Pi is also used for the process of taking photos and videos. This study using the Raspberry Pi Camera Module V2. This module is specially made as an add-on board for Raspberry Pi using Sony IMX219 with 8 Megapixel image sensor. The interface used is the CSI interface [19]. The solenoid door lock is used to lock server room doors. To activate and deactivate the solenoid, it can be done in two ways, using an RFID card or entering a password via keypad 4x4. In this system, the keypad used is a 4x4 keypad, while the RFID reader used is MFRC-522. This MFRC-522 module works at a frequency of 13.56 MHz and can be used with ISO14443A standard RFID tags. The interface used to communicate with this module is to use 4 pin SPI [20].

In this system, the telegram application is used so that users can interact with the tool. Telegram itself is a free and multiplatform messaging media application. By using telegram, users can send photos, audio, video, and other file types. The greatest advantage of Telegram is that it is open source and open source API support. With these advantages, many users use this app. One of the features used by Telegram in this study is the Telegram Bot API. This bot is a third party application that can run on the Telegram application [21].

After getting materials and tools suitable for use according to the block diagram, a design is made regarding the placement of each component of this tool. The tool placement design is shown in figure 2.

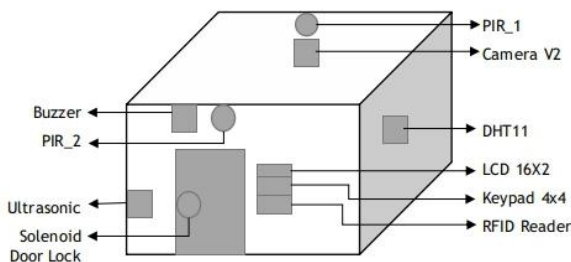

Fig. 2 Design of component placement in the server room

The next part is the flowchart of this system. The flowchart shown in Figure 3 is an outline of how this system works and becomes the basis for making programs for this system.

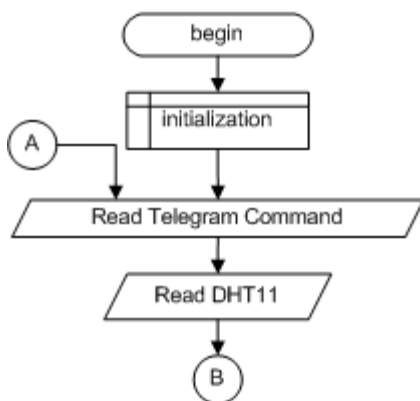

Fig. 3 Flowchart system

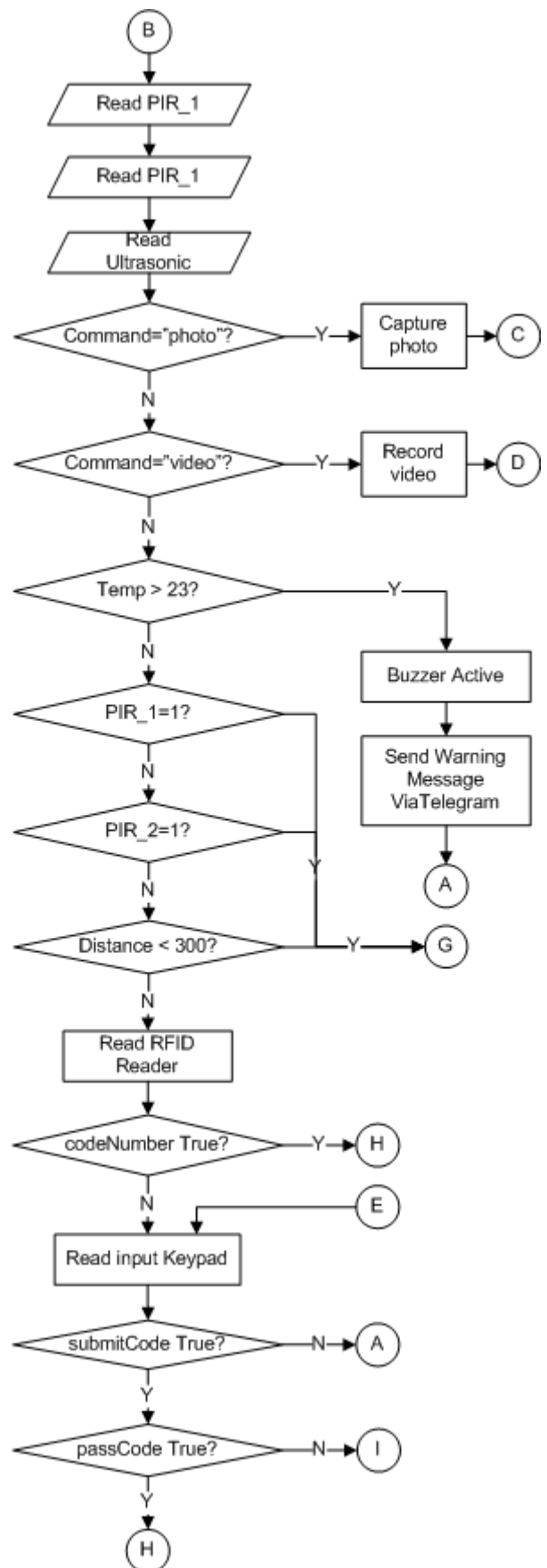

Fig. 3 Flowchart system (continue)

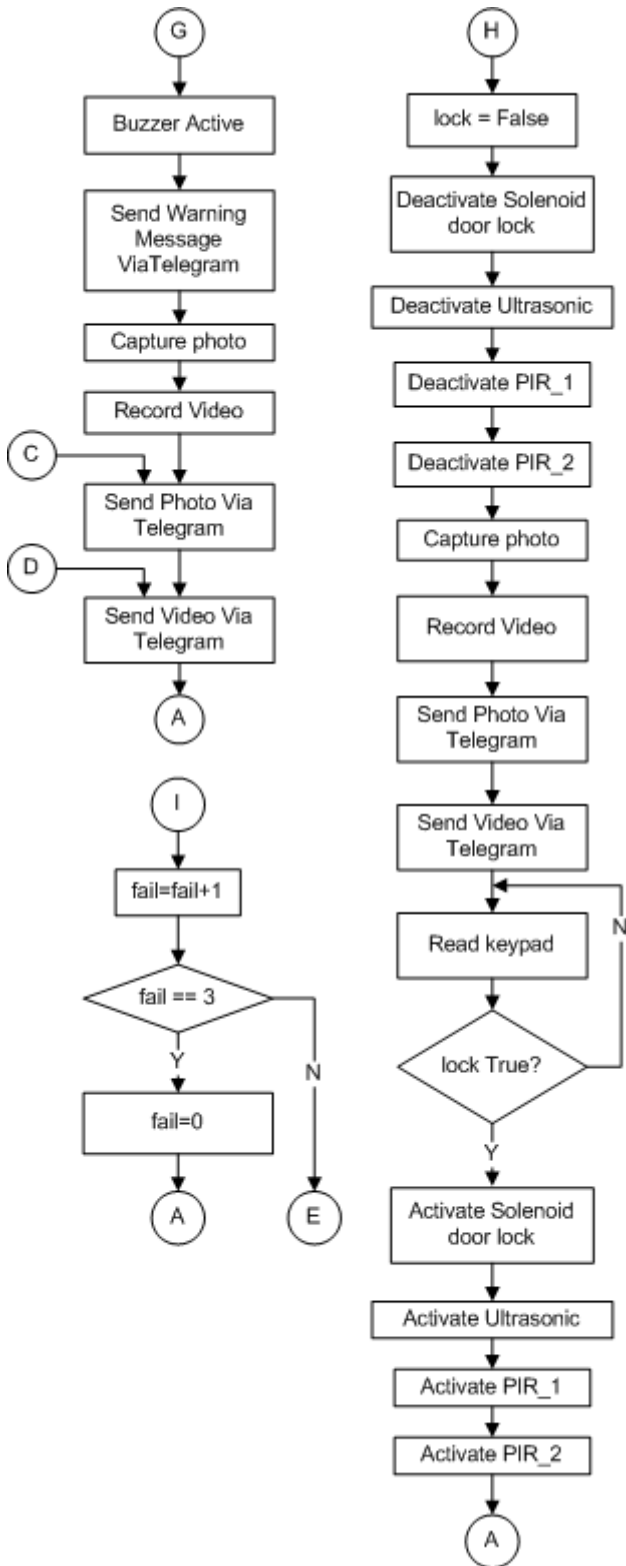

Fig. 3 Flowchart system (continue)

From Figure 3 above, the program flow of this tool can be explained. When it is first turned on, the Raspberry Pi will first check whether there is an order from the user sent via telegram. Furthermore, if an order is received, Raspberry will store it in a variable. All output from both the DHT11, PIR\_1, PIR\_2 and ultrasonic sensors will be read by the Raspberry Pi. All readings are stored in variables first. Next, all variables will be compared. If there is a "photo"

command, the Raspberry Pi will take a photo at that time and send the results to the user via telegram. If there is a "video" command, the Raspberry Pi will take the current video and send the results to the user via telegram. If the measured temperature is more than 23<sup>0</sup>C, the Raspberry Pi will send a warning message to the user via telegram. If the PIR\_1 sensor or PIR\_2 sensor detects movement, the Raspberry Pi will send warning messages, photos, and videos to the user via telegram. If the distance read from the ultrasonic sensor is less than 300cm, the Raspberry Pi will send warning messages, photos, and videos to the user via telegram. When all the parts above are safe, the Raspberry Pi will read data from the RFID reader regarding the door opening which of course involves deactivating the solenoid door lock, PIR\_1 sensor, PIR\_2 sensor, and ultrasonic sensor. Raspberry will also take photos and videos at that time for documentation purposes related to people accessing the server room. If the user forgets to bring his RFID tag, then the user can still enter the server room by entering the password via the 4x4 keypad. The opportunity to enter this password is 3 times. The next process that occurs when the password is recognized is the same as the process when the RFID tag is recognized. If the user leaves the server room and locks the door using the keypad, all previously deactivated things such as the solenoid door lock, PIR\_1 sensor, PIR\_2 sensor, and ultrasonic sensor will be activated again.

### III. RESULTS AND DISCUSSION

The tests carried out in this study include 3 parts, namely testing the giving of commands to test the response of the tool, testing when access rights are valid, and testing when an intruder tries to enter the server room.

#### A. Testing Commands

After all the parts of this tool are installed in the server room, the test command sent via the telegram application is carried out. This serves to ensure that the Raspberry Pi can read commands sent by users and the Raspberry Pi responds according to the commands given.

The initial command to start the bot is "/start". When receiving this command, the Raspberry Pi must respond by providing some information regarding how to use the bot command using this telegram application. The results of this test are shown in Figure 4.

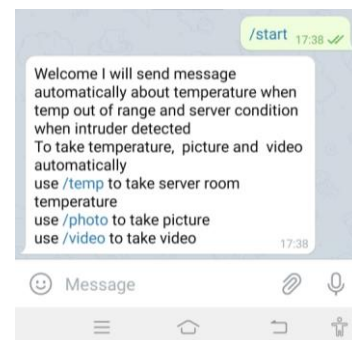

Fig. 4 Test "/start" command

The next test is testing every command that has been determined on the tool. The commands tested were the commands "/temp", "/photo" and "/video". Command

"/temp" is used to get the measured temperature at that time. The command "/photo" is used to get a photo in the current server room. The command "/video" is used to get the video in the current server room. Each test on this command is performed 10 times.

Table 1 shows the test "/temp" command performed. When the user sends the "/temp" command, the Raspberry Pi will send the current measured temperature and humidity values 10 times.

TABLE I  
A COMMAND FOR ACTUAL TEMPERATURE AND HUMIDITY

Test No.	Command (Send)	Time (Send)	Response received	Time (Receive)
1.	/temp	17:38	√	17:38
2.	/temp	19:32	√	19:32
3.	/temp	20:11	√	20:11
4.	/temp	20:45	√	20:45
5.	/temp	21:10	√	21:10
6.	/temp	08:00	√	08:00
7.	/temp	08:30	√	08:30
8.	/temp	10:00	√	10:00
9.	/temp	12:15	√	12:15
10.	/temp	13:00	√	13:00

The time for testing the "/temp" command is varied, it is also intended to check that the tool is still running. From the test results in table 1, it can be seen that all the "/temp" commands sent have been responded to well by the tool with a 100% success percentage from 10 testings. Figure 5 shows one of the results obtained when the user sends the command "/temp" via the telegram application.



Fig. 5 Testing to get actual temperature and humidity

The next test is testing the photo and video capture requests manually using the "/photo" and "/video"

commands. Table 2 shows the tests performed for the "/photo" command.

TABLE III  
THE COMMAND FOR TAKING PICTURE MANUALLY

Test No.	Command (Send)	Time (Send)	Photo received	Time (Receive)
1.	/photo	15:35	√	15:35
2.	/photo	16:30	√	16:30
3.	/photo	18:20	√	18:20
4.	/photo	19:00	√	19:00
5.	/photo	20:50	√	20:50
6.	/photo	21:15	√	21:15
7.	/photo	07:40	√	07:40
8.	/photo	09:28	√	09:28
9.	/photo	10:18	√	10:18
10.	/photo	10:50	√	10:50

When the test is carried out regarding the "/photo" command, it is carried out in various ways, it is also intended to check that the tool is still working. From the test results in table 2, it can be seen that all the "/photo" commands sent have been responded to well by the tool with a 100% success percentage from 10 testings. One example of the photos sent by the Raspberry Pi is shown in Figure 6.

The next step is to test the video sending request command regarding the current server room situation using the "/video" command. Table 3 shows the test "/video" command that was performed.

TABLE IIIII  
THE COMMAND FOR TAKING VIDEO MANUALLY

Test No.	Command (Send)	Time (Send)	Video received	Time (Receive)
1.	/video	16:45	√	16:46
2.	/video	17:05	√	17:05
3.	/video	18:00	√	18:01
4.	/video	18:20	√	18:20
5.	/video	19:15	√	19:15
6.	/video	21:00	√	21:01
7.	/video	08:36	√	08:36
8.	/video	09:10	√	09:11
9.	/video	10:15	√	10:16
10.	/video	12:05	√	12:05

The recording duration in this test is 15 seconds. The time for testing the "/video" command is varied, it is also intended to check that the tool is still working. From the test results in table 3, it can be seen that all "/video" commands sent have been responded to well by the tool with a 100% success percentage from 10 testings. Figure 6 above shows one of the video results that was successfully taken and sent to the bot telegram.



Fig. 6 Testing to get actual photo and video of the server room

Testing of all commands that exist in this system has been successful 100% following every testing process that has been carried out.

### B. Testing Regarding Valid Access

The next test is a test related to valid access. This test involves 3 users who have been given an RFID tag card with the test code names T1, T2, and T3. In this test, the user will “tap” the card to enter the server room. If the card is recognized, the door lock solenoid and all sensors are not active and Raspberry sends photos and videos to the admin. In this testing process, testing was also carried out using an unrecognized RFID tag card with the card name "T4" (not registered in the system). The test results are shown in Table 4.

TABLE IVV  
RFID TAG TESTING

Desc.	RFID tag Recognized	Solenoid door lock	PIR 1	PIR 2	Ultra sonic	Photo and Video
T1	√	x	x	x	x	Sent
T2	√	x	x	x	x	Sent
T3	√	x	x	x	x	Sent
T4	x	√	√	√	√	No
T4	x	√	√	√	√	No
T2	√	x	x	x	x	Sent
T3	√	x	x	x	x	Sent
T4	x	√	√	√	√	No
T4	x	√	√	√	√	No
T1	√	x	x	x	x	Sent

From the test results shown in table 3 it can be explained that when the RFID card tag is recognized, the door lock solenoid will be deactivated so that the door can be opened.

Furthermore, the PIR\_1 sensor, PIR\_2 sensor, and Ultrasonic sensor are also deactivated and the Raspberry Pi sends photos and videos when this happens. When the RFID tag is not recognized, the opposite happens where all actuators and sensors remain active. Of the 10 times, this testing process is all successful with a success percentage of 100%.

The next testing process is testing access to the server room using a password that is input via the 4x4 keypad. This test is performed 10 times by entering the passwords of 3 users. Recognized passwords are given the test code names P1, P2, and P3. The unknown passcode is given the test code name P4. Table 5 shows the results of the tests carried out.

TABLE V  
KEYPAD PASSWORD TESTING

Desc.	Password Recognized	Solenoid door lock	PIR 1	PIR 2	Ultra sonic	Photo and Video
P3.	√	x	x	x	x	Sent
P4	x	√	√	√	√	No
P1	√	x	x	x	x	Sent
P2	√	x	x	x	x	Sent
P4	x	√	√	√	√	No
P1	√	x	x	x	x	Sent
P2	√	x	x	x	x	Sent
P4	x	√	√	√	√	No
P3	√	x	x	x	x	Sent
P1	√	x	x	x	x	Sent

The test results in table 5 show that when the input password is recognized, the door lock solenoid, sensorPIR\_1, PIR\_2 sensor, and ultrasonic sensor will be deactivated. In other words, the user can enter the server room. At the same time, the Raspberry Pi will also take photos and videos then send them to the admin.

When the wrong password is entered, the actuator and all sensors remain active and the unauthorized person cannot enter the server room. Raspberry Pi also will not send photos and videos at that time because indeed the server room is locked and no one is detected in the server room.

### C. Testing Regarding Invalid Temperature and Intruder Detection

The next part of the test is testing when something goes wrong in the server room, such as the temperature is out of the predetermined limits and when an intruder enters the server room.

The first test is a test related to temperatures that are outside the predetermined limits. Wherein in this system, the specified threshold is 210C-230C. The Raspberry Pi must send a message to the telegram bot when this happens. Figure 7 shows the test results in the form of a warning message received by the admin.





Fig. 7 Warning messages regarding temperature

The next test is testing when an intruder is detected entering from the front door. This means that an intruder breaks the front door to get into the server room. The distance read will automatically decrease. Furthermore, the Raspberry Pi will activate a warning buzzer and send a message to the telegram bot. Warning messages are sent in the form of text messages, photos, and videos. Figure 8 shows the messages received when this occurred.

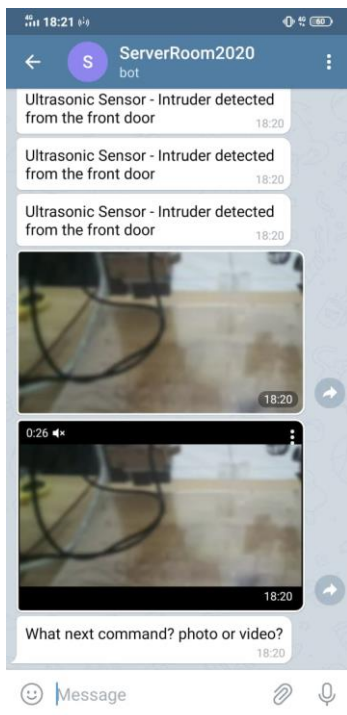

Fig. 8 Warning message regarding intruder from the front door

The next test is testing related to the PIR\_1 sensor and PIR\_2 sensor. This test aims to detect intruders who force their way through the roof or damage the back of the server room. When this happens, the intruder's movement will be detected by one or both of the PIR sensors. Figure 9 shows the message received by the user when an intruder is detected by the PIR\_1 sensor or the PIR\_2 sensor.



Fig. 9 Warning message regarding intruder detected with PIR sensor

Messages received by users are warning messages in the form of text, photos, and videos. After finishing sending all messages, the bot will wait for further instructions from the user. Commands can be in the form of commands to record and resend video or take photos. All these tests were successful and following the objectives and program scenarios.

Based on all test results, this tool has fulfilled the objective where this tool can monitor the condition and security of the server room by utilizing IoT technology, while in other studies it only focuses on temperature and humidity [6] - [10], and other studies only focus on door locks only [11].

#### IV. CONCLUSIONS

The server room can be monitored both for its condition and security by implementing IoT and utilizing the telegram API. This tool has been running well with a success percentage of 100% following the tests carried out. With this tool, users can also maintain access to the server room and will immediately receive a warning via Telegram bot when something goes wrong in the server room.

#### REFERENCES

- [1] L. Vladimir, "Building Secure IT Server Room", Finland: Laurea University of Applied Sciences, pp 48-49, 2013.

- [2] L. Fuguo, "Study on security and prevention strategies of computer network" in International Conference on Computer Science and Information Processing (CSIP), 2012, pp. 645-647, DOI: 10.1109/CSIP.2012.6308936.
- [3] B. Sarpong and Z. Li, "Computer Network Security: Risks and Protective Measures", American Journal of Engineering Research (AJER), vol. 8, Issue:5, pp-52-58, e-ISSN: 2320-0847 p-ISSN: 2320-0936, 2019 .
- [4] F. H. Purwanto, E. Utami, and E Pramono, "Implementation and Optimization of Server Room Temperature and Humidity Control System using Fuzzy Logic Based on Microcontroller" in IOP Conf. Series: Journal of Physics: Conf. Series 1140, 2018.
- [5] Government Computer Security Incident Response Team (Gov-CSIRT), "STANDARD OPERATING PROCEDURE Incident Handling Infrastruktur Fisik Indonesia Direktorat Keamanan Informasi Direktorat Jendral Aplikasi Informatika, Jakarta: KEMKOMINFO, p.25, 2017.
- [6] U. A. Nizam, B. T. Zahari, B. M. K. Ismail, M. F. Rabbi, S. A. M. Matior, and S. Kenneth, "Fuzzy Logic Controller Design for Intelligent Air-Conditioning System" in 2nd International Conference on Control Science and Systems Engineering, p 232-236, 2016.
- [7] T. R. Dwi, E. S. Didik, D. L. Pringgo, and J. Anif, "The design of an embedded system for controlling humidity and temperature room" in 8th International Conference on Physics and its Applications(ICOPIA), vol. 776, p.1-3, 2016.
- [8] K. Sophiya, P. Kenneth, and S. Jude, "Temperature and humidity monitoring and alert management system", International Journal of Engineering Research and General Science, vol. 4, issue 4, pp. 349-351, 2016.
- [9] S. J. Jabbar, "Design and simulation of automatic temperature control and alert system based PIC16F887", International Journal of Informatics and Communication Technology (IJ-ICT), vol. 6 no. 2, pp. 95-104, 2017.
- [10] S. A. u. R. Omer and E. Muhammad, "Design of intelligent air conditioner controller using fuzzy logic," International Conference on Innovations in Electrical Engineering and Computational Technologies (ICIEECT), pp. 1-5, 2017, DOI: 10.1109/ICIEECT.2017.7916556.
- [11] S. Niraj, K. Kamlesh, W. Pankaj, S. Danish, and G. Arvind, "Server Room Access Control Using Smartphone", International Journal of Engineering and Techniques, vol. 4 issue 3, pp. 56-59, May- June 2018 ISSN: 2395-1303.
- [12] M. A. P. Utomo, A. Aziz, Winarno, and B. Harjito, "Server Room Temperature & Humidity Monitoring Based on Internet of Thing (IoT)", IOP Conf. Series: Journal of Physics: Conf. Series 1306 (2019) 012030, doi:10.1088/1742-6596/1306/1/012030 ]
- [13] M. F. Wicaksono, Syahrul, M. D. Rahmatya, and M. A. F. Rahman, "Raspberry Pi-based Solar System Learning Media", IOP Conf. Series: Materials Science and Engineering 879 (2020) 012022, doi:10.1088/1757-899X/879/1/012022
- [14] S. R. Vijayalakshmi, and S. Muruganand, "Real Time Monitoring of Wireless Fire Detection Node", Procedia Technology, Volume 24, Pages 1113-1119, ISSN 2212-0173, 2016, <https://doi.org/10.1016/j.protcy.2016.05.244>.
- [15] S. B. Saleh, S. B. Mazlan, N. I. B. Hamzah, A. Z. Z. B. A. Karim, M. S. B. Zainal, S. A. B. Hamzah, D. B. M. Nor, and H. B. M. Poad, "Smart Home Security Access System Using Field Programmable Gate Arrays", Indonesian Journal of Electrical Engineering and Computer Science, vol.11, no.1, pp. 152~160, July 2018, ISSN: 2502-4752, DOI: 10.11591/ijeecs.v11.i1.pp152-160
- [16] T. Sysala, D. Fogl, and P. Neumann, "The family house control system based on Raspberry Pi", MATEC Web of Conferences 125, 02034 (2017), pp. 1-7, 2017.
- [17] R. Firdaus, and E. Mulyana, "Smart Building Lighting System", IOP Conf. Ser.: Mater. Sci. Eng.384 012071, 2018.
- [18] M. Mutinda, P. K Kamweru, "Arduino Uno, Ultrasonic Sensor HC-SR04 Motion Detector with Display of Distance in the LCD", International Journal of Engineering and Technical Research, vol.9, issue 5, pp. 936-941, May 2020.
- [19] M. A. Pagnutti, R. E. Ryan, G. J. V. Cazenavette, J. G. Maxwell, R. Harlan, E. Leggett, and J. F. Pagnutti, "Laying the foundation to use Raspberry Pi 3 V2 camera module imagery for scientific and engineering purposes", Journal of Electronic Imaging, vol. 26, issue:1, pp. 1-13,11 February 2017, <https://doi.org/10.1117/1.JEI.26.1.013014>
- [20] O. Gaikwad, Sp. Prajwal, M. Kantimanhanti, "RFID AttendanceUsing RC522", International Journal of Scientific & Engineering Research Volume 11, issue: 5, pp. 949-954, May-2020, ISSN 2229-5518
- [21] Sucipto, N. C. Resti, T. Andriyanto, J. Karaman, and R. S. Qamaria, "Transactional database design information system web-based tracer study integrated telegram bot", Journal of Physics: Conference Series1381 (2019) 012008 IOP Publishing, 2019, doi:10.1088/1742-6596/1381/1/012008.

# REVIEW



M Fajar Wicaksono <mfajarw@email.unikom.ac.id>

---

## [IJASEIT] Revision Required

1 message

---

**Rahmat Hidayat** <rahmat@insightsociety.org>

Sat, Jun 12, 2021 at 6:16 AM

To: "Mr. Mochamad Fajar Wicaksono" <mfajarw@email.unikom.ac.id>

Mr. Mochamad Fajar Wicaksono:

We have reached a decision regarding your submission to International Journal on Advanced Science, Engineering and Information Technology, "IoT Implementation for Server Room Security Monitoring Using Telegram API".

Our decision is to: Revision Required

Please update your abstract into 220-250 words and your reference 70% in (2017-2021) from journal indexed by Scopus. Citation and Reference in Paper must using Mendeley with IEEE Style.

Please submit your revision (Template IJASEIT 2021) in 10 days. More than 10 days of paper will be rejected from the system. Re-upload your revision into journal system NOT via email.

Editor

-----  
Reviewer A:

Improve your abstract 200-250 words, with data results and conclusion. Give the schematic/diagram process of the research method/step systematically. In writing, there are still errors in making tables that are not in accordance with the latest journal template in 2021. Fix it by referring to the template. Also fix images with proper proportionality, legible size and good image quality (300 dpi). This improvement also includes how you display figures and tables properly and proportionally, for example only 3-4 images and 2-3 tables are displayed.

Pay attention your references : Reference must be 70% in (2017-2021) from journal indexed by Scopus. Citation and Reference in Paper must using Mendeley with IEEE Style.

-----  
International Journal on Advanced Science, Engineering and Information Technology

<http://insightsociety.org/ijaseit/index.php/ijaseit>

# IoT Implementation for Server Room Security Monitoring Using Telegram API

M. F. Wicaksono<sup>a</sup>, M. D. Rahmatya<sup>b</sup>, Ilham<sup>c</sup>

<sup>a</sup>Program Studi Teknik Komputer, Universitas Komputer Indonesia, Jl. Dipati Ukur 112-116, Bandung, Indonesia

<sup>b</sup>Program Studi Manajemen Informatika, Universitas Komputer Indonesia, Jl. Dipati Ukur 112-116, Bandung, Indonesia

<sup>c</sup>Program Studi Sistem Komputer, Universitas Komputer Indonesia, Jl. Dipati Ukur 112-116, Bandung, Indonesia

\*Corresponding author: mfajarw@email.unikom.ac.id

---

**Abstract**— The purpose of this research is to create a system that can monitor server room security by utilizing IoT technology, controllers, sensors, actuators, and Telegram API. The system made includes security for the indoor and outdoor parts. The method used in this study is experimental. The output obtained by the user is telegram text messages, photos, and video. The main controller on this system is the Raspberry Pi. The result of this study showed that if the server room temperature is  $>23^{\circ}\text{C}$  then the system will send a message via telegram. If the PIR sensor\_1 or PIR sensor\_2 detects an intruder or the measured distance is  $<300\text{cm}$  from the side of the door, the system will send text messages, photos, and videos via telegram. That way the user can determine the next steps related to the condition of the server room. However, if the RFID tag is recognized, the solenoid door lock, PIR, and ultrasonic will be deactivated. Other features, Users can ask the system to record a video of the room conditions and also messages related to room temperature through commands sent via Telegram messages. Testing is carried out using 3 scenarios, namely testing command, testing regarding valid access, and testing regarding invalid temperature and intruder detection. Overall test results show all these tests were successful 100% and following the objectives and program scenarios. This tool has fulfilled the objective where this tool can monitor the condition and security of the server room by utilizing IoT technology.

**Keywords**— IoT; Server Room; Monitoring; Raspberry Pi; Telegram

Manuscript received 8 Dec. 2020; revised 19 Jun. 2021; accepted xx xxx. 2021. Date of publication xx xxx. 2021.  
IJASEIT is licensed under a Creative Commons Attribution-Share Alike 4.0 International License.



## I. INTRODUCTION

The server room is used to store servers that contain applications and databases. Keeping the server room safe is very important because it is a data center that stores all information related to company operations. Today, security can mean either physical security, as in physical access control or logical security. Physical security is needed to avoid physical attacks on the server room. One form of physical attack on the server room is an abuse of privilege. This attack requires illegal access to the system physically such as physical breaches and theft. Related to physical security, procedures or mechanisms are needed to prevent physical attacks. A well-built management strategy can counter espionage and theft [1]. The prevention mechanism can also minimize risk, find the cause of the damage, and determine the appropriate steps to overcome it. Implementation of physical security and effective policies and procedures are as important as staff awareness [2].

Server rooms can be monitored remotely by implementing the Internet of Things (IoT). IoT enables the collection and sharing of data with other devices over the internet. With IoT, information is collected, stored, and can be used for data analysis processes [3]. In a government decree, it is stated that temperature and humidity in the server room are some of the important things to monitor [4]. In Indonesia, there are already standards related to temperature and humidity set by the government in 2017. The standard temperature is in the range of  $21^{\circ}\text{C}$ - $23^{\circ}\text{C}$  and humidity is in the range of 45% to 60%. High humidity can cause corrosion and short circuits. Apart from temperature and humidity, there are many other things related to server room security that must be monitored, mainly related to defense mechanisms.

A lot of research is related to this server room both for monitoring and for security. Research in 2017 is also still focused on the problem of temperature and humidity and no features related to warnings messages are given to users [5]. A study in 2017 has added fuzzy logic to design intelligent air

conditioners. However, it just focuses on temperature [6]. Furthermore, in the same year, namely 2018, there was research on this server room. However, this research only focuses on the security of the server room door by using an application and a door lock [7]. In 2019 there was new research related to this server room which was able to send notification messages via the Telegram application. However, these studies only focus on temperature and humidity [8].

Nearly all of the previous studies focused on one part of server room temperature and humidity and one that focused solely on server room entrances. So, in general, no one directly discusses monitoring the conditions and security of the server room.

In this research, a system will be made to monitor the condition and security of the server room. The security scope of this research is the inside and the outside of the server room. The output that the user will get is telegram text messages and video telegrams. The main controller on this system is the Raspberry Pi. Raspberry Pi will read input from ultrasonic sensors, PIR sensors, DHT11 sensors, and cameras. The PIR sensor is here used to detect human presence in the server room. In this study, two PIR sensors were used which were placed across from each other inside the server room. DHT11 sensor is used to measure the temperature of the server room. If the temperature is outside the threshold, the user will get a message related to this and the buzzer in the room will also be active. On the outside, placed the RFID reader and keypad. This is related to access rights to the server room. If the password is entered or the RFID tag is recognized, the Raspberry Pi will deactivate the solenoid door lock to open the door and turn off the ultrasonic sensor and all PIR sensors. Users can ask the device to record a video of the room conditions and also messages related to room temperature through commands sent via Telegram messages. If there is an incident, for example, the door is forcibly opened, the distance the ultrasonic sensor reads will get smaller, so the Raspberry Pi will activate the buzzer and send a telegram message to the user regarding the incident. Then Raspberry will wait for the next command. The next action is obtained from the telegram message sent by the user. This can be a request for a video recording related to the current condition or a photo taken at that time.

## II. MATERIALS AND METHODS

As mentioned above, IoT technology can be implemented and utilized to monitor the condition of a room from afar, especially in this case, the server room. The research method used is the experimental method.

In the implementation process, a series of designs, simulations, and experiments were carried out directly following the theoretical studies that had previously been carried out to obtain the expected results following the test scenario to achieve the initial objectives of the research. The stages of the research carried out are shown in Fig. 1.

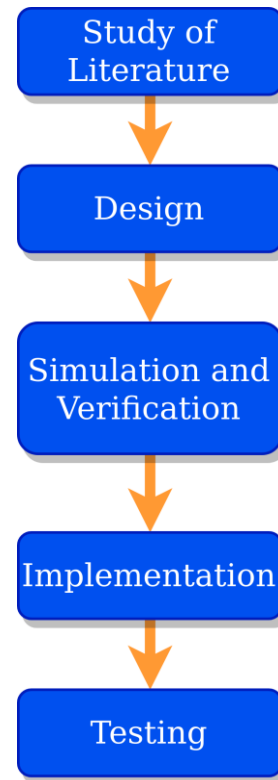

Fig. 1 Diagram process of the research methods

### A. Study of Literature

The first step is to conduct a literature study related to server rooms, research related to server rooms, and determine the system requirements to be made related to hardware and software.

### B. Design

At this stage, design related to hardware, software, and mechanical design is carried out based on theoretical studies that have been carried out in the previous stage.

In this study, the Raspberry Pi 3B is used as the main brain of the system which will process all input and output. Raspberry Pi 3B is a mini PC and it has peripheral ports and GPIO pins [9]. It has SoC BCM2837 and 1GB RAM [10]. Raspberry Pi can be used for both monitoring and controlling [11]. Python language is used to create programs on the Raspberry Pi [12]. The input part of this system includes a DHT11 sensor, two PIR sensors, an ultrasonic sensor, an RFID reader, a keypad, and a camera module. On the other hand, the output includes Buzzer, 16x2 LCD, Relay, and Solenoid Door Lock. This telegram messaging application functions as input and output on this system. In the hardware design section, a block diagram is generated that shows the overall system architecture as shown in Fig. 2.

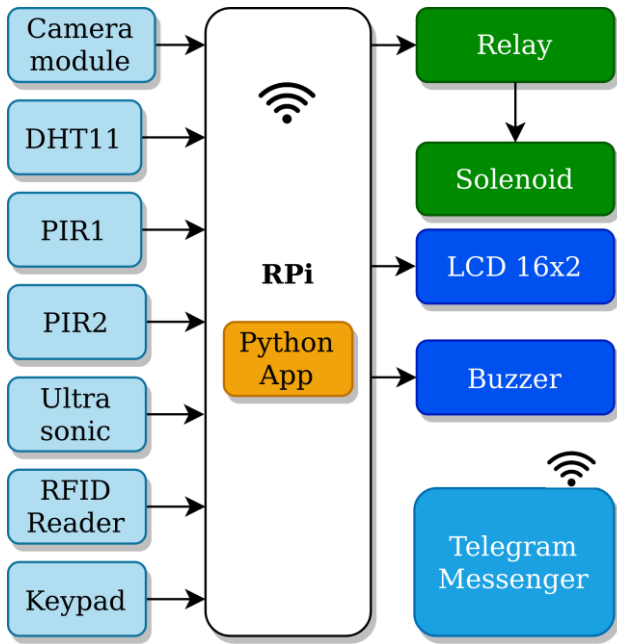

Fig. 2 System Block Diagram IoT Implementation for Server Room Security Monitoring Using Telegram API

DHT11 is a sensor module that can be used to measure temperature and humidity [13], [14]. The temperature measurement range on this sensor is 0°C-50°C. The humidity measurement range on this sensor is 20%-90% [14]. This sensor has a high level of accuracy and can be easily integrated into a system [15]. In this study, DHT11 is placed in the server room and data from DHT11 will be read by Raspberry Pi. PIR sensor is a type of motion sensor [16]. To detect human movement, we can use this sensor [17]. This study uses the PIR HC-SR501 sensor module. This sensor module has digital output [18]. In this study, two HC-SR501 sensors were used. The two sensors are placed opposite in the server room. In this case, it is intended to detect intruders who enter the server room via the roof. Ultrasonic sensors are commonly used to measure distances. In this study, the HC-SR04 ultrasonic sensor was used. This ultrasonic sensor works by sending sound pulses with a high frequency [19]. The measured distance is obtained from the initial time of sending the ultrasonic signal until it is received at the echo pin then multiplied by the speed of sound (340m/s) and finally divided by 2 [20]. The distance that can be measured with this sensor is 2cm to 4m [21]. In this study, the HC-SR04 ultrasonic sensor was placed on the wall in the room near the entrance. The sensor will send a legible distance to the Raspberry Pi. If there are thieves who try to enter by breaking the entrance, the incident will be immediately known because the distance read by the ultrasonic sensor is outside the range specified in the program. Furthermore, the Raspberry Pi will activate the buzzer and send a message to the user regarding the incident. A special camera module for the Raspberry Pi is also used for the process of taking photos and videos. This study using the Raspberry Pi Camera Module V2. This module using Sony IMX219 with 8 Megapixel image sensor [22]. This module has 1us exposure time and provides 200FPS for video [23]. The solenoid door lock is used to lock server room doors. To activate and deactivate the solenoid, it can be done in two ways, using an RFID card or entering a password via keypad 4x4. In this system, the keypad used is a

4x4 keypad, while the RFID reader used is MFRC-522. This RFID uses electromagnetic fields to work [24]. This MFRC-522 module works at a frequency of 13.56 MHz Tag reading distance between 3cm-5cm [25]. Communication with this module is done via the SPI pin. [26], [27].

In this system, the telegram application is used so that users can interact with the tool. Telegram is a free instant messaging application and can be used on various platforms [28]. In this application, users can send various types of data such as images, videos, and others. The advantage of this application is open source API and users can create bots for their needs. One of the features used by Telegram in this study is the Telegram Bot API. This bot is a third-party application that can run on the Telegram application [29].

Based on the theoretical studies obtained and the block diagrams that have been made, the next step is to translate these shapes into a circuit design to realize this system as shown in. Fig. 3.

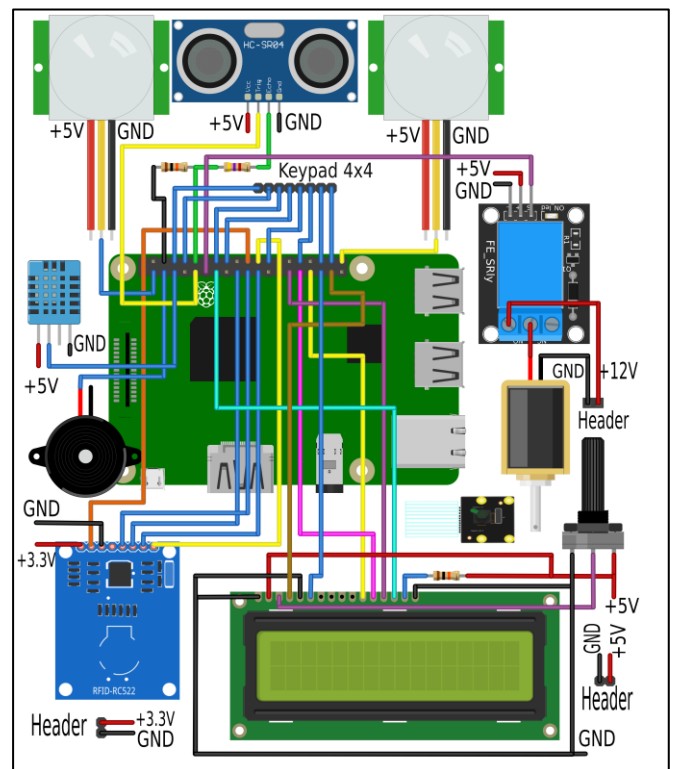

Fig. 3 The electronic circuit of IoT Implementation for Server Room Security Monitoring Using Telegram API

After creating a series of systems, the next step is software design. At this stage, an algorithm is created to create a Python program for this system. The following algorithm is an outline and illustrates how this system will work:

1. Begin
2. GPIO and variable initialization
3. Read incoming command from Telegram
4. Read DHT11, PIR1 sensor, PIR2 sensor, Ultrasonic sensor
5. If command="/photo" then
  - capture photo and send it via telegram
  - back to step 3
6. If command="/video" then
  - capture video and send it via telegram
  - back to step 3

7. If temp > 23 then
  - activate a buzzer, send a warning message via telegram, and go to step 3
8. If PIR1=1 then go to point 17
9. If PIR2=1 then go to point 17
10. If distance < 300 then go to point 17
11. Read RFID reader
12. If code number recognized, then go to step 13
13. Access granted procedure:
  - give False value to lock variable
  - deactivate solenoid door lock,
  - deactivate DHT11,
  - deactivate sensor PIR1,
  - deactivate sensor PIR2,
  - deactivate sensor ultrasonic.
  - Capture photo and video.
  - Send photo and video via telegram.
  - Read keypad
  - If lock = False, then read keypad again
  - If lock = True, then
    - activate solenoid door lock,
    - activate DHT11,
    - activate sensor PIR1,
    - activate sensor PIR2,
    - activate sensor ultrasonic.
    - back to step 3
14. If code number not recognized, then read input keypad
15. If input password from keypad True, then go to step 13
16. If input password from keypad false 3 times, then go to step 3
17. Activate buzzer, send warning message via telegram, capture photo, record video, send photo and video via telegram. After that, back to step 3.

From the algorithm above, the program flow of this tool can be explained. When it is first turned on, the Raspberry Pi will first check whether there is an order from the user sent via telegram. Furthermore, if an order is received, Raspberry will store it in a variable. All output from both the DHT11, PIR\_1, PIR\_2, and ultrasonic sensors will be read by the Raspberry Pi. All readings are stored in variables first. Next, all variables will be compared. If there is a "photo" command, the Raspberry Pi will take a photo at that time and send the results to the user via telegram. If there is a "video" command, the Raspberry Pi will take the current video and send the results to the user via telegram. If the measured temperature is more than 23°C, the Raspberry Pi will send a warning message to the user via telegram. If the PIR\_1 sensor or PIR\_2 sensor detects movement, the Raspberry Pi will send warning messages, photos, and videos to the user via telegram. If the distance read from the ultrasonic sensor is less than 300cm, the Raspberry Pi will send warning messages, photos, and videos to the user via telegram. When all the parts above are safe, the Raspberry Pi will read data from the RFID reader regarding the door opening which of course involves deactivating the solenoid door lock, PIR\_1 sensor, PIR\_2 sensor, and ultrasonic sensor. Raspberry will also take photos and videos at that time for documentation purposes related to people accessing the server room. If the user forgets to bring his RFID tag, then the user can still enter the server room by

entering the password via the 4x4 keypad. The opportunity to enter this password is 3 times. The next process that occurs when the password is recognized is the same as the process when the RFID tag is recognized. If the user leaves the server room and locks the door using the keypad, all previously deactivated things such as the solenoid door lock, PIR\_1 sensor, PIR\_2 sensor, and ultrasonic sensor will be activated again.

After getting materials and tools suitable for use according to the block diagram, a design is made regarding the placement of each component of this tool. The tool placement design is shown in Fig. 4.

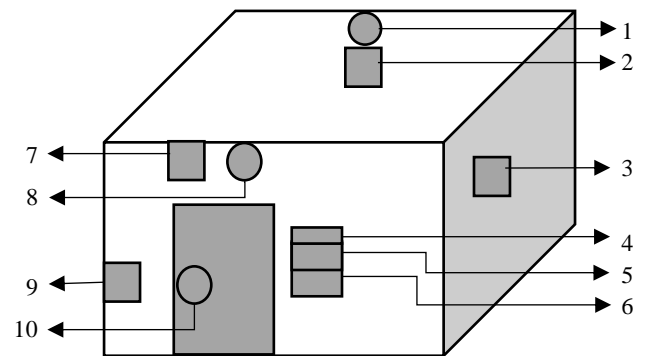

Fig. 4 Design of component placement in the server room

The following is a description of the names of all hardware components placed according to Fig. 4 in this study:

1. PIR1 sensor
2. Raspberry Pi and Pi Camera V2
3. DHT11 sensor
4. LCD 16x2
5. Keypad
6. RFID Reader
7. Buzzer
8. PIR2 sensor
9. Ultrasonic sensor
10. Solenoid Door Lock

### C. Simulation and Verification

At this stage, hardware and software simulations are carried out based on schematics and programs that have been made in the previous stage. Simulation is in the form of debugging this system program and verifying the circuit according to the schematic.

### D. Implementation

At this stage, all hardware and software are combined so that there is synchronization between the two things to suit the initial objectives of this research.

### E. Testing

At this stage, testing is carried out on the system created by testing the functionality of the tool based on commands sent from the telegram application and testing the system according to the scenario created.

## III. RESULTS AND DISCUSSION

The tests carried out in this study include 3 parts, namely testing the giving of commands to test the response of the tool,



testing when access rights are valid, and testing when an intruder tries to enter the server room.

#### A. Testing Commands

After all the parts of this tool are installed in the server room, the test command sent via the telegram application is carried out. This serves to ensure that the Raspberry Pi can read commands sent by users and the Raspberry Pi responds according to the commands given.

The initial command to start the bot is "/start". When receiving this command, the Raspberry Pi must respond by providing some information regarding how to use the bot command using this telegram application. The results of this test are shown in Fig. 5.

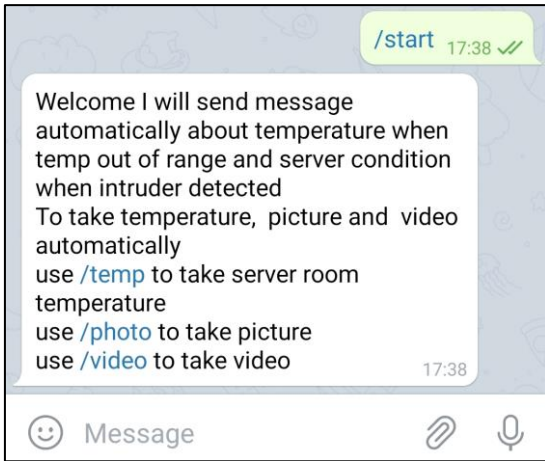

Fig. 5 Test "/start" command

The next test is testing every command that has been determined on the tool. The commands tested were the commands "/temp", "/photo" and "/video". Command "/temp" is used to get the measured temperature at that time. The command "/photo" is used to get a photo in the current server room. The command "/video" is used to get the video in the current server room. Each test on this command is performed 10 times.

When the user sends the "/temp" command, the Raspberry Pi will send the current measured temperature and humidity values 10 times. The test results for the "/temp" command are shown in Table 1.

TABLE I  
A COMMAND FOR ACTUAL TEMPERATURE AND HUMIDITY

Test No.	Command (Send)	Time (Send)	Response received	Time (Receive)
1.	/temp	17:38	√	17:38
2.	/temp	19:32	√	19:32
3.	/temp	20:11	√	20:11
4.	/temp	20:45	√	20:45
5.	/temp	21:10	√	21:10
6.	/temp	08:00	√	08:00
7.	/temp	08:30	√	08:30
8.	/temp	10:00	√	10:00
9.	/temp	12:15	√	12:15
10.	/temp	13:00	√	13:00

The time for testing the "/temp" command is varied, it is also intended to check that the tool is still running. From the test results in table 1, it can be seen that all the "/temp"

commands sent have been responded to well by the tool with a 100% success percentage from 10 testings.

The next test is testing the photo and video capture requests manually using the "/photo" and "/video" commands. The test results for this command are shown in Table 2.

TABLE II  
THE COMMAND FOR TAKING PICTURE MANUALLY

Test No.	Command (Send)	Time (Send)	Photo received	Time (Receive)
1.	/photo	15:35	√	15:35
2.	/photo	16:30	√	16:30
3.	/photo	18:20	√	18:20
4.	/photo	19:00	√	19:00
5.	/photo	20:50	√	20:50
6.	/photo	21:15	√	21:15
7.	/photo	07:40	√	07:40
8.	/photo	09:28	√	09:28
9.	/photo	10:18	√	10:18
10.	/photo	10:50	√	10:50

When the test is carried out regarding the "/photo" command, it is carried out in various ways, it is also intended to check that the tool is still working. From the test results in table 2, it can be seen that all the "/photo" commands sent have been responded to well by the tool with a 100% success percentage from 10 testings.

The next step is to test the video sending request command regarding the current server room situation using the "/video" command. The test results for the "/video" command that was performed are shown in Table 3.

TABLE III  
THE COMMAND FOR TAKING VIDEO MANUALLY

Test No.	Command (Send)	Time (Send)	Video received	Time (Receive)
1.	/video	16:45	√	16:46
2.	/video	17:05	√	17:05
3.	/video	18:00	√	18:01
4.	/video	18:20	√	18:20
5.	/video	19:15	√	19:15
6.	/video	21:00	√	21:01
7.	/video	08:36	√	08:36
8.	/video	09:10	√	09:11
9.	/video	10:15	√	10:16
10.	/video	12:05	√	12:05

The recording duration in this test is 15 seconds. The time for testing the "/video" command is varied, it is also intended to check that the tool is still working. From the test results in table 3, it can be seen that all "/video" commands sent have been responded to well by the tool with a 100% success percentage from 10 testings.

Testing of all commands that exist in this system has been successful 100% following every testing process that has been carried out.

#### B. Testing Regarding Valid Access

The next test is a test related to valid access. This test involves 3 users who have been given an RFID tag card with the test code names T1, T2, and T3. In this test, the user will "tap" the card to enter the server room. If the card is recognized, the door lock solenoid and all sensors are not active and Raspberry sends photos and videos to the admin.

In this testing process, testing was also carried out using an unrecognized RFID tag card with the card name "T4" (not registered in the system). The test results are shown in Table 4.

TABLE IV  
RFID TAG TESTING

Desc	RFID tag Recognized	Solenoid door lock	PIR 1	PIR 2	Ultra sonic	Photo and Video
T1	√	x	x	x	x	Sent
T2	√	x	x	x	x	Sent
T3	√	x	x	x	x	Sent
T4	x	√	√	√	√	No
T4	x	√	√	√	√	No
T2	√	x	x	x	x	Sent
T3	√	x	x	x	x	Sent
T4	x	√	√	√	√	No
T4	x	√	√	√	√	No
T1	√	x	x	x	x	Sent

From the test results shown in table 3 it can be explained that when the RFID card tag is recognized, the door lock solenoid will be deactivated so that the door can be opened. Furthermore, the PIR\_1 sensor, PIR\_2 sensor, and Ultrasonic sensor are also deactivated and the Raspberry Pi sends photos and videos when this happens. When the RFID tag is not recognized, the opposite happens where all actuators and sensors remain active. Of the 10 times, this testing process is all successful with a success percentage of 100%.

The next testing process is testing access to the server room using a password that is input via the 4x4 keypad. This test is performed 10 times by entering the passwords of 3 users. Recognized passwords are given the test code names P1, P2, and P3. The unknown passcode is given the test code name P4. The test results related to these access rights are shown in the Table 5.

TABLE V  
KEYPAD PASSWORD TESTING

Desc	Password Recognized	Solenoid door lock	PIR 1	PIR 2	Ultra sonic	Photo and Video
P3.	√	x	x	x	x	Sent
P4	x	√	√	√	√	No
P1	√	x	x	x	x	Sent
P2	√	x	x	x	x	Sent
P4	x	√	√	√	√	No
P1	√	x	x	x	x	Sent
P2	√	x	x	x	x	Sent
P4	x	√	√	√	√	No
P3	√	x	x	x	x	Sent
P1	√	x	x	x	x	Sent

The test results in table 5 show that when the input password is recognized, the door lock solenoid, PIR\_1 sensor, PIR\_2 sensor, and ultrasonic sensor will be deactivated. In other words, the user can enter the server room. At the same time, the Raspberry Pi will also take photos and videos then send them to the admin.

When the wrong password is entered, the actuator and all sensors remain active and the unauthorized person cannot enter the server room. Raspberry Pi also will not send photos

and videos at that time because indeed the server room is locked and no one is detected in the server room.

### C. Testing Regarding Invalid Temperature and Intruder Detection

The first test is a test related to temperatures that are outside the predetermined limits. Wherein in this system, the specified threshold is 21<sup>0</sup>C-23<sup>0</sup>C. The Raspberry Pi must send a message to the telegram bot when this happens. The test results in the form of a warning message received by the admin are shown in Fig. 6.

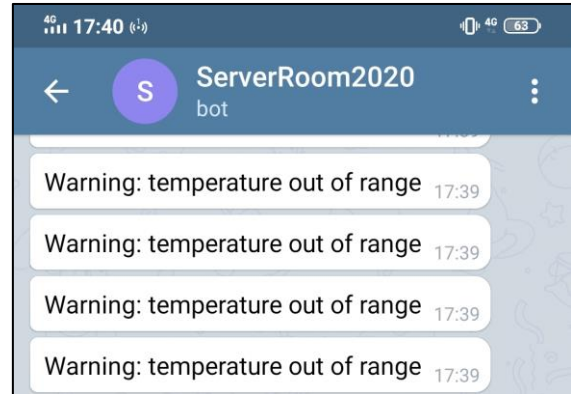

Fig. 6. Warning messages regarding temperature

The next test is testing when an intruder is detected entering from the front door. This means that an intruder breaks the front door to get into the server room. The distance read will automatically decrease. Furthermore, the Raspberry Pi will activate a warning buzzer and send a message to the telegram bot. Warning messages are sent in the form of text messages, photos, and videos. The message given by the system when this happens is shown in the Fig.7.



Fig. 7 Warning message regarding intruder from the front door

The next test is testing related to the PIR\_1 sensor and PIR\_2 sensor. This test aims to detect intruders who force their way through the roof or damage the back of the server room. When this happens, the intruder's movement will be detected by one or both of the PIR sensors. The message received by the user when an intruder is detected by the PIR\_1 sensor or the PIR\_2 sensor are shown in Fig. 8.



Fig. 8 Warning message regarding intruder detected with PIR sensor

Messages received by users are warning messages in the form of text, photos, and videos. After finishing sending all messages, the bot will wait for further instructions from the user. Commands can be in the form of commands to record and resend video or take photos. All these tests were successful and following the objectives and program scenarios.

Based on all test results, this tool has fulfilled the objective where this tool can monitor the condition and security of the server room by utilizing IoT technology, while in other studies it only focuses on temperature and humidity [5], [6], [8], and other studies only focus on door locks only [7].

#### IV. CONCLUSION

The server room can be monitored both for its condition and security by implementing IoT and utilizing the telegram API. This tool has been running well with a success

percentage of 100% following the tests carried out. With this tool, users can also maintain access to the server room and will immediately receive a warning via Telegram bot when something goes wrong in the server room. For further research development, it may be possible to add face detection features and the number of people in the server room.

#### REFERENCES

- [1] J. P. A. Yaacoub, O. Salman, H. N. Noura, N. Kaaniche, A. Chehab, and M. Malli, "Cyber-physical systems security: Limitations, issues and future trends," *Microprocess. Microsyst.*, vol. 77, pp. 1–45, Sep. 2020, doi: 10.1016/j.micpro.2020.103201.
- [2] I. Ghafir *et al.*, "Security threats to critical infrastructure: the human factor," *J. Supercomput.*, vol. 74, pp. 4986–5002, 2018, doi: 10.1007/s11227-018-2337-2.
- [3] N. Scarpato, A. Pieroni, L. Di Nunzio, and F. Fallucchi, "E-health-IoT universe: A review," *Int. J. Adv. Sci. Eng. Inf. Technol.*, vol. 7, no. 6, pp. 2328–2336, 2017, doi: 10.18517/ijaseit.7.6.4467.
- [4] Menteri Hukum Dan Hak Asasi Manusia, "Pedoman Penyelenggaraan Pusat Data Dan Ruang Server Di Lingkungan Kementerian Hukum Dan Hak Asasi Manusia Republik Indonesia," Indonesia, M.HH-01.TI.05.02, 2017. [Online]. Available: [https://www.kemendikham.go.id/attachments/article/1522/Keppm en Tentang Pedoman Penyelenggaraan Pusat Data dan Ruang Server - final.pdf](https://www.kemendikham.go.id/attachments/article/1522/Keppm%20tentang%20Pedoman%20Penyelenggaraan%20Pusat%20Data%20dan%20Ruang%20Server%20-%20final.pdf).
- [5] J. S. Jahlool, "Design and Simulation of Automatic Temperature Control and Alert System Based PIC16F887," *Int. J. Informatics Commun. Technol.*, vol. 6, no. 2, pp. 95–104, Aug. 2017, doi: 10.11591/ijict.v6i2.pp95-104.
- [6] S. A. u. R. Omer and E. Muhammad, "Design of intelligent air conditioner controller using fuzzy logic," in *2017 International Conference on Innovations in Electrical Engineering and Computational Technologies (ICIEECT)*, 2017, pp. 1–5, doi: 10.1109/ICIEECT.2017.7916556.
- [7] S. Niraj, K. Kamlesh, W. Pankaj, S. Danish, and G. Arvind, "Server Room Access Control Using Smartphone," *Int. J. Eng. Tech.*, vol. 4, no. 3, pp. 56–59, 2018, [Online]. Available: <http://www.ijetjournal.org>.
- [8] M. Alvan, P. Utomo, A. Aziz, and B. Harjito, "Server Room Temperature & Humidity Monitoring Based on Internet of Thing (IoT)," in *Journal of Physics: Conference Series*, 2019, pp. 1–8, doi: 10.1088/1742-6596/1306/1/012030.
- [9] J. Sobota, M. Goubej, J. Königsmarková, and M. Čech, "Raspberry Pi-based HIL simulators for control education," *IFAC-PapersOnLine*, vol. 52, no. 9, pp. 68–73, 2019, doi: <https://doi.org/10.1016/j.ifacol.2019.08.126>.
- [10] V. Chauhan, M. Patel, S. Tanwar, S. Tyagi, and N. Kumar, "IoT Enabled real-Time urban transport management system," *Comput. Electr. Eng.*, vol. 86, pp. 1–18, 2020, doi: <https://doi.org/10.1016/j.compeleceng.2020.106746>.
- [11] H. Hidayat, N. S. Hasibuan, and F. Wicaksono, "Design And Implementation Of Electronic Examination Device For Improving The Blind Students' Comfort," *J. Eng. Sci. Technol.*, vol. 16, no. 1, pp. 807–815, 2021, [Online]. Available: <https://jestec.taylors.edu.my/V16Issue1.htm>.
- [12] N. Bafdal and I. Ardiansah, "Application of Internet of Things in Smart Greenhouse Microclimate Management for Tomato Growth," *Int. J. Adv. Sci. Eng. Inf. Technol.*, vol. 11, no. 2, pp. 427–432, 2021, doi: 10.18517/ijaseit.11.2.13638.
- [13] T. Zou *et al.*, "Raspberry promotes brown and beige adipocyte development in mice fed high-fat diet through activation of AMP-activated protein kinase (AMPK)  $\alpha 1$ ," *J. Nutr. Biochem.*, vol. 55, pp. 157–164, 2018, doi: <https://doi.org/10.1016/j.jnutbio.2018.02.005>.
- [14] M. T. A. Seman, M. N. Abdullah, and M. K. Ishak, "Monitoring Temperature, Humidity And Controlling System In Industrial Fixed Room Storage Based On IoT," *J. Eng. Sci. Technol.*, vol. 15, no. 6, pp. 3588–3600, 2020, [Online]. Available: <https://jestec.taylors.edu.my/V15Issue6.htm>.
- [15] I. Ardiansah, N. Bafdal, E. Suryadi, and A. Bono, "Greenhouse monitoring and automation using arduino: A review on precision farming and Internet of Things (IoT)," *Int. J. Adv. Sci. Eng. Inf. Technol.*, vol. 10, no. 2, pp. 703–709, 2020, doi: 10.18517/ijaseit.10.2.10249.

- [16] M. Jacob and P. Mani, "A Reference Model For Testing Internet of Things Based Applications," *J. Eng. Sci. Technol.*, vol. 13, no. 8, pp. 2504–2519, 2018, [Online]. Available: <https://jestec.taylors.edu.my/V13Issue8.htm>.
- [17] S. Bin Saleh *et al.*, "Smart home security access system using field programmable gate arrays," *Indones. J. Electr. Eng. Comput. Sci.*, vol. 11, no. 1, pp. 152–160, 2018, doi: 10.11591/ijeecs.v11.i1.pp152-160.
- [18] M. Murad, O. Bayat, and H. M. Marhoon, "Design and implementation of a smart home system with two levels of security based on IoT technology," *Indones. J. Electr. Eng. Comput. Sci.*, vol. 21, no. 1, pp. 546–557, 2021, doi: 10.11591/ijeecs.v21.i1.pp546-557.
- [19] S. Nuanmeesri and L. Poomhira, "Optimization Shortest One-Way Path for Energy Saving Auto Robot Collecting Floating Garbage using Fast Approximate Nearest Neighbor Search," *Int. J. Adv. Sci. Eng. Inf. Technol.*, vol. 11, no. 2, pp. 457–464, 2021, doi: 10.18517/ijaseit.11.2.13191.
- [20] L. Benny and P. K. Soori, "Prototype of parking finder application for intelligent parking system," *Int. J. Adv. Sci. Eng. Inf. Technol.*, vol. 7, no. 4, pp. 1185–1190, 2017, doi: 10.18517/ijaseit.7.4.2326.
- [21] O. Appiah, E. Quayson, and E. Opoku, "Ultrasonic sensor based traffic information acquisition system; a cheaper alternative for ITS application in developing countries," *Sci. African*, vol. 9, p. e00487, 2020, doi: <https://doi.org/10.1016/j.sciaf.2020.e00487>.
- [22] X. Mouy *et al.*, "FishCam: A low-cost open source autonomous camera for aquatic research," *HardwareX*, vol. 8, p. e00110, 2020, doi: <https://doi.org/10.1016/j.ohx.2020.e00110>.
- [23] K. Miikki *et al.*, "An open-source camera system for experimental measurements," *SoftwareX*, vol. 14, p. 100688, 2021, doi: <https://doi.org/10.1016/j.softx.2021.100688>.
- [24] J. AnnRoseela and T. Godhvari, "Biometric and RFID based authentication system for exam paper leakages detection using IoT technology," *Indones. J. Electr. Eng. Comput. Sci.*, vol. 20, no. 3, pp. 1271–1277, 2020, doi: 10.11591/ijeecs.v20.i3.pp1271-1277.
- [25] M. El Beqqal, M. Azizi, and J. L. Lanet, "Multimodal access control system combining RFID, fingerprint and facial recognition," *Indones. J. Electr. Eng. Comput. Sci.*, vol. 20, no. 1, pp. 405–413, 2020, doi: 10.11591/ijeecs.v20.i1.pp405-413.
- [26] M. Vagaš, A. Galajdová, D. Šimšák, and D. Onofrejová, "Wireless data acquisition from automated workplaces based on RFID technology," *IFAC-PapersOnLine*, vol. 52, no. 27, pp. 299–304, 2019, doi: <https://doi.org/10.1016/j.ifacol.2019.12.677>.
- [27] M. K. Kah Wen, N. binti Ahmad, and S. H. binti Ruslan, "Arduino based outing and attendance system for boarding school students," *Indones. J. Electr. Eng. Comput. Sci.*, vol. 20, no. 2, pp. 1053–1061, 2020, doi: 10.11591/ijeecs.v20.i2.pp1053-1061.
- [28] N. Jannati, N. Nakhaee, V. Yazdi-Feyzabadi, and D. Tjondronegoro, "A cross-sectional online survey on patients' satisfaction using store-and-forward voice and text messaging teleconsultation service during the COVID-19 pandemic," *Int. J. Med. Inform.*, vol. 151, p. 104474, 2021, doi: <https://doi.org/10.1016/j.ijmedinf.2021.104474>.
- [29] A. Dargahi Nobari, M. H. K. M. Sarraf, M. Neshati, and F. Erfanian Daneshvar, "Characteristics of viral messages on Telegram; The world's largest hybrid public and private messenger," *Expert Syst. Appl.*, vol. 168, p. 114303, 2021, doi: <https://doi.org/10.1016/j.eswa.2020.114303>.

**ACCEPTED**



M Fajar Wicaksono <mfajarw@email.unikom.ac.id>

---

## [IJASEIT] Editor Decision

1 message

---

**Rahmat Hidayat** <rahmat@insightsociety.org>

Mon, Jul 5, 2021 at 6:38 AM

To: "Mr. Mochamad Fajar Wicaksono" <mfajarw@email.unikom.ac.id>

Mr. Mochamad Fajar Wicaksono:

We have reached a decision regarding your submission to International Journal on Advanced Science, Engineering and Information Technology, "IoT Implementation for Server Room Security Monitoring Using Telegram API".

Our decision is to: Accepted Submission

Rahmat Hidayat

[rahmat@insightsociety.org](mailto:rahmat@insightsociety.org) / [mr.rahmat@gmail.com](mailto:mr.rahmat@gmail.com)

-----  
Reviewer A:

This paper already has novelty and good contributions in accordance with existing research objectives. Abstract writing is correct and provides good information about the research objectives, the methods used and the research results. The writing is in accordance with the provisions, namely the maximum number of words is 250 words. The introduction is good with a clear background and has a strong gap in analysis. The introduction has also contained the latest research and good contributions in accordance with the objectives of the research being studied. The research method is clear and systematic, with systematic stages and has a good flow chart. The discussion is good and already has clear and complete arguments with arguments that refer to relevant and current journals. The making of figures and tables is in accordance with the 2021 template. The conclusions are good and clear, and are in accordance with the objectives. Reference is relevant and precise and in accordance with the main study of research.

-----  
International Journal on Advanced Science, Engineering and Information Technology

<http://insightsociety.org/ijaseit/index.php/ijaseit>

# IoT Implementation for Server Room Security Monitoring Using Telegram API

M. F. Wicaksono<sup>a</sup>, M. D. Rahmatya<sup>b</sup>, Ilham<sup>c</sup>

<sup>a</sup>Program Studi Teknik Komputer, Universitas Komputer Indonesia, Jl. Dipati Ukur 112-116, Bandung, Indonesia

<sup>b</sup>Program Studi Manajemen Informatika, Universitas Komputer Indonesia, Jl. Dipati Ukur 112-116, Bandung, Indonesia

<sup>c</sup>Program Studi Sistem Komputer, Universitas Komputer Indonesia, Jl. Dipati Ukur 112-116, Bandung, Indonesia

\*Corresponding author: mfajarw@email.unikom.ac.id

---

**Abstract**— The purpose of this research is to create a system that can monitor server room security by utilizing IoT technology, controllers, sensors, actuators, and Telegram API. The system made includes security for the indoor and outdoor parts. The method used in this study is experimental. The output obtained by the user is telegram text messages, photos, and video. The main controller on this system is the Raspberry Pi. The result of this study showed that if the server room temperature is  $>23^{\circ}\text{C}$  then the system will send a message via telegram. If the PIR sensor\_1 or PIR sensor\_2 detects an intruder or the measured distance is  $<300\text{cm}$  from the side of the door, the system will send text messages, photos, and videos via telegram. That way the user can determine the next steps related to the condition of the server room. However, if the RFID tag is recognized, the solenoid door lock, PIR, and ultrasonic will be deactivated. Other features, Users can ask the system to record a video of the room conditions and also messages related to room temperature through commands sent via Telegram messages. Testing is carried out using 3 scenarios, namely testing command, testing regarding valid access, and testing regarding invalid temperature and intruder detection. Overall test results show all these tests were successful 100% and following the objectives and program scenarios. This tool has fulfilled the objective where this tool can monitor the condition and security of the server room by utilizing IoT technology.

**Keywords**— IoT; Server Room; Monitoring; Raspberry Pi; Telegram

*Manuscript received 8 Dec. 2020; revised 19 Jun. 2021; accepted 05 Aug. 2021. Date of publication xx xxx. 2021. IJASEIT is licensed under a Creative Commons Attribution-Share Alike 4.0 International License.*



## I. INTRODUCTION

The server room is used to store servers that contain applications and databases. Keeping the server room safe is very important because it is a data center that stores all information related to company operations. Today, security can mean either physical security, as in physical access control or logical security. Physical security is needed to avoid physical attacks on the server room. One form of physical attack on the server room is an abuse of privilege. This attack requires illegal access to the system physically such as physical breaches and theft. Related to physical security, procedures or mechanisms are needed to prevent physical attacks. A well-built management strategy can counter espionage and theft [1]. The prevention mechanism can also minimize risk, find the cause of the damage, and determine the appropriate steps to overcome it. Implementation of physical security and effective policies and procedures are as important as staff awareness [2].

Server rooms can be monitored remotely by implementing the Internet of Things (IoT). IoT enables the collection and sharing of data with other devices over the internet. With IoT, information is collected, stored, and can be used for data analysis processes [3]. In a government decree, it is stated that temperature and humidity in the server room are some of the important things to monitor [4]. In Indonesia, there are already standards related to temperature and humidity set by the government in 2017. The standard temperature is in the range of  $21^{\circ}\text{C}$ - $23^{\circ}\text{C}$  and humidity is in the range of 45% to 60%. High humidity can cause corrosion and short circuits. Apart from temperature and humidity, there are many other things related to server room security that must be monitored, mainly related to defense mechanisms.

A lot of research is related to this server room both for monitoring and for security. Research in 2017 is also still focused on the problem of temperature and humidity and no features related to warnings messages are given to users [5]. A study in 2017 has added fuzzy logic to design intelligent air

conditioners. However, it just focuses on temperature [6]. Furthermore, in the same year, namely 2018, there was research on this server room. However, this research only focuses on the security of the server room door by using an application and a door lock [7]. In 2019 there was new research related to this server room which was able to send notification messages via the Telegram application. However, these studies only focus on temperature and humidity [8].

Nearly all of the previous studies focused on one part of server room temperature and humidity and one that focused solely on server room entrances. So, in general, no one directly discusses monitoring the conditions and security of the server room.

In this research, a system will be made to monitor the condition and security of the server room. The security scope of this research is the inside and the outside of the server room. The output that the user will get is telegram text messages and video telegrams. The main controller on this system is the Raspberry Pi. Raspberry Pi will read input from ultrasonic sensors, PIR sensors, DHT11 sensors, and cameras. The PIR sensor is here used to detect human presence in the server room. In this study, two PIR sensors were used which were placed across from each other inside the server room. DHT11 sensor is used to measure the temperature of the server room. If the temperature is outside the threshold, the user will get a message related to this and the buzzer in the room will also be active. On the outside, placed the RFID reader and keypad. This is related to access rights to the server room. If the password is entered or the RFID tag is recognized, the Raspberry Pi will deactivate the solenoid door lock to open the door and turn off the ultrasonic sensor and all PIR sensors. Users can ask the device to record a video of the room conditions and also messages related to room temperature through commands sent via Telegram messages. If there is an incident, for example, the door is forcibly opened, the distance the ultrasonic sensor reads will get smaller, so the Raspberry Pi will activate the buzzer and send a telegram message to the user regarding the incident. Then Raspberry will wait for the next command. The next action is obtained from the telegram message sent by the user. This can be a request for a video recording related to the current condition or a photo taken at that time.

## II. MATERIALS AND METHODS

As mentioned above, IoT technology can be implemented and utilized to monitor the condition of a room from afar, especially in this case, the server room. The research method used is the experimental method.

In the implementation process, a series of designs, simulations, and experiments were carried out directly following the theoretical studies that had previously been carried out to obtain the expected results following the test scenario to achieve the initial objectives of the research. The stages of the research carried out are shown in Fig. 1.

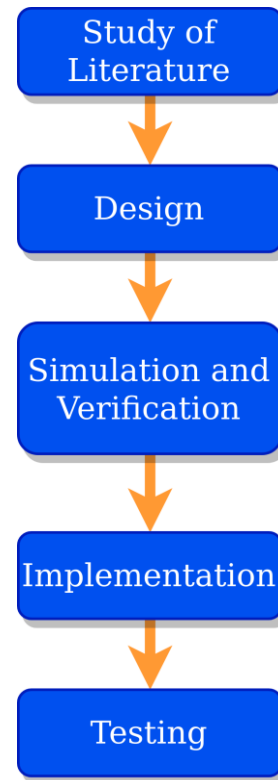

Fig. 1 Diagram process of the research methods

### A. Study of Literature

The first step is to conduct a literature study related to server rooms, research related to server rooms, and determine the system requirements to be made related to hardware and software.

### B. Design

At this stage, design related to hardware, software, and mechanical design is carried out based on theoretical studies that have been carried out in the previous stage.

In this study, the Raspberry Pi 3B is used as the main brain of the system which will process all input and output. Raspberry Pi 3B is a mini PC and it has peripheral ports and GPIO pins [9]. It has SoC BCM2837 and 1GB RAM [10]. Raspberry Pi can be used for both monitoring and controlling [11]. Python language is used to create programs on the Raspberry Pi [12]. The input part of this system includes a DHT11 sensor, two PIR sensors, an ultrasonic sensor, an RFID reader, a keypad, and a camera module. On the other hand, the output includes Buzzer, 16x2 LCD, Relay, and Solenoid Door Lock. This telegram messaging application functions as input and output on this system. In the hardware design section, a block diagram is generated that shows the overall system architecture as shown in Fig. 2.



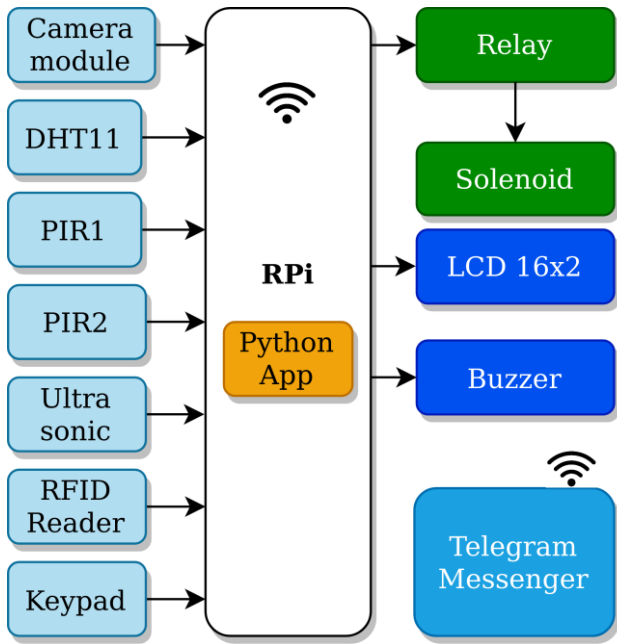

Fig. 2 System Block Diagram IoT Implementation for Server Room Security Monitoring Using Telegram API

DHT11 is a sensor module that can be used to measure temperature and humidity [13], [14]. The temperature measurement range on this sensor is 0°C-50°C. The humidity measurement range on this sensor is 20%-90% [14]. This sensor has a high level of accuracy and can be easily integrated into a system [15]. In this study, DHT11 is placed in the server room and data from DHT11 will be read by Raspberry Pi. PIR sensor is a type of motion sensor [16]. To detect human movement, we can use this sensor [17]. This study uses the PIR HC-SR501 sensor module. This sensor module has digital output [18]. In this study, two HC-SR501 sensors were used. The two sensors are placed opposite in the server room. In this case, it is intended to detect intruders who enter the server room via the roof. Ultrasonic sensors are commonly used to measure distances. In this study, the HC-SR04 ultrasonic sensor was used. This ultrasonic sensor works by sending sound pulses with a high frequency [19]. The measured distance is obtained from the initial time of sending the ultrasonic signal until it is received at the echo pin then multiplied by the speed of sound (340m/s) and finally divided by 2 [20]. The distance that can be measured with this sensor is 2cm to 4m [21]. In this study, the HC-SR04 ultrasonic sensor was placed on the wall in the room near the entrance. The sensor will send a legible distance to the Raspberry Pi. If there are thieves who try to enter by breaking the entrance, the incident will be immediately known because the distance read by the ultrasonic sensor is outside the range specified in the program. Furthermore, the Raspberry Pi will activate the buzzer and send a message to the user regarding the incident. A special camera module for the Raspberry Pi is also used for the process of taking photos and videos. This study using the Raspberry Pi Camera Module V2. This module using Sony IMX219 with 8 Megapixel image sensor [22]. This module has 1us exposure time and provides 200FPS for video [23]. The solenoid door lock is used to lock server room doors. To activate and deactivate the solenoid, it can be done in two ways, using an RFID card or entering a password via keypad 4x4. In this system, the keypad used is a

4x4 keypad, while the RFID reader used is MFRC-522. This RFID uses electromagnetic fields to work [24]. This MFRC-522 module works at a frequency of 13.56 MHz Tag reading distance between 3cm-5cm [25]. Communication with this module is done via the SPI pin. [26], [27].

In this system, the telegram application is used so that users can interact with the tool. Telegram is a free instant messaging application and can be used on various platforms [28]. In this application, users can send various types of data such as images, videos, and others. The advantage of this application is open source API and users can create bots for their needs. One of the features used by Telegram in this study is the Telegram Bot API. This bot is a third-party application that can run on the Telegram application [29].

Based on the theoretical studies obtained and the block diagrams that have been made, the next step is to translate these shapes into a circuit design to realize this system as shown in. Fig. 3.

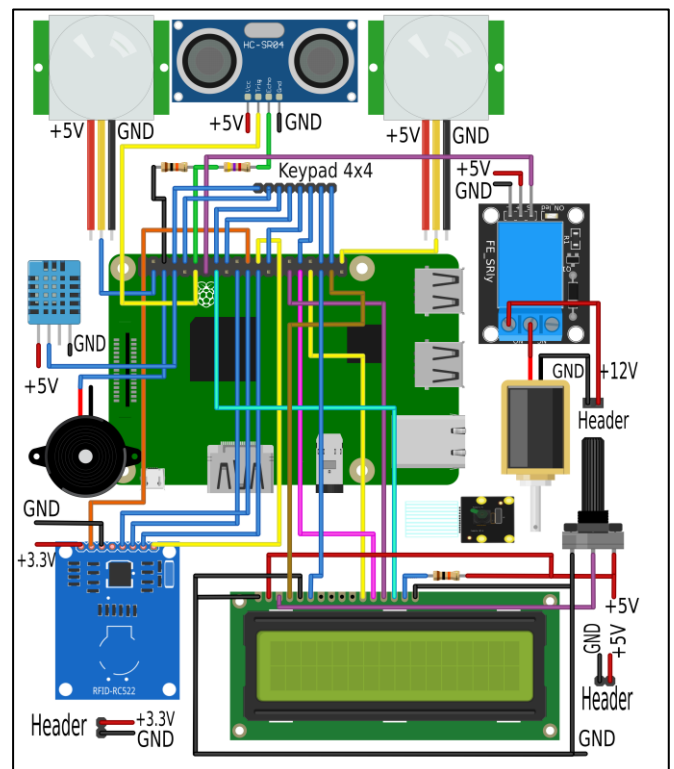

Fig. 3 The electronic circuit of IoT Implementation for Server Room Security Monitoring Using Telegram API

After creating a series of systems, the next step is software design. At this stage, an algorithm is created to create a Python program for this system. The following algorithm is an outline and illustrates how this system will work:

1. Begin
2. GPIO and variable initialization
3. Read incoming command from Telegram
4. Read DHT11, PIR1 sensor, PIR2 sensor, Ultrasonic sensor
5. If command="/photo" then
  - capture photo and send it via telegram
  - back to step 3
6. If command="/video" then
  - capture video and send it via telegram
  - back to step 3

7. If temp > 23 then
  - activate a buzzer, send a warning message via telegram, and go to step 3
8. If PIR1=1 then go to point 17
9. If PIR2=1 then go to point 17
10. If distance < 300 then go to point 17
11. Read RFID reader
12. If code number recognized, then go to step 13
13. Access granted procedure:
  - give False value to lock variable
  - deactivate solenoid door lock,
  - deactivate DHT11,
  - deactivate sensor PIR1,
  - deactivate sensor PIR2,
  - deactivate sensor ultrasonic.
  - Capture photo and video.
  - Send photo and video via telegram.
  - Read keypad
  - If lock = False, then read keypad again
  - If lock = True, then
    - activate solenoid door lock,
    - activate DHT11,
    - activate sensor PIR1,
    - activate sensor PIR2,
    - activate sensor ultrasonic.
    - back to step 3
14. If code number not recognized, then read input keypad
15. If input password from keypad True, then go to step 13
16. If input password from keypad false 3 times, then go to step 3
17. Activate buzzer, send warning message via telegram, capture photo, record video, send photo and video via telegram. After that, back to step 3.

From the algorithm above, the program flow of this tool can be explained. When it is first turned on, the Raspberry Pi will first check whether there is an order from the user sent via telegram. Furthermore, if an order is received, Raspberry will store it in a variable. All output from both the DHT11, PIR\_1, PIR\_2, and ultrasonic sensors will be read by the Raspberry Pi. All readings are stored in variables first. Next, all variables will be compared. If there is a "photo" command, the Raspberry Pi will take a photo at that time and send the results to the user via telegram. If there is a "video" command, the Raspberry Pi will take the current video and send the results to the user via telegram. If the measured temperature is more than 23°C, the Raspberry Pi will send a warning message to the user via telegram. If the PIR\_1 sensor or PIR\_2 sensor detects movement, the Raspberry Pi will send warning messages, photos, and videos to the user via telegram. If the distance read from the ultrasonic sensor is less than 300cm, the Raspberry Pi will send warning messages, photos, and videos to the user via telegram. When all the parts above are safe, the Raspberry Pi will read data from the RFID reader regarding the door opening which of course involves deactivating the solenoid door lock, PIR\_1 sensor, PIR\_2 sensor, and ultrasonic sensor. Raspberry will also take photos and videos at that time for documentation purposes related to people accessing the server room. If the user forgets to bring his RFID tag, then the user can still enter the server room by

entering the password via the 4x4 keypad. The opportunity to enter this password is 3 times. The next process that occurs when the password is recognized is the same as the process when the RFID tag is recognized. If the user leaves the server room and locks the door using the keypad, all previously deactivated things such as the solenoid door lock, PIR\_1 sensor, PIR\_2 sensor, and ultrasonic sensor will be activated again.

After getting materials and tools suitable for use according to the block diagram, a design is made regarding the placement of each component of this tool. The tool placement design is shown in Fig. 4.

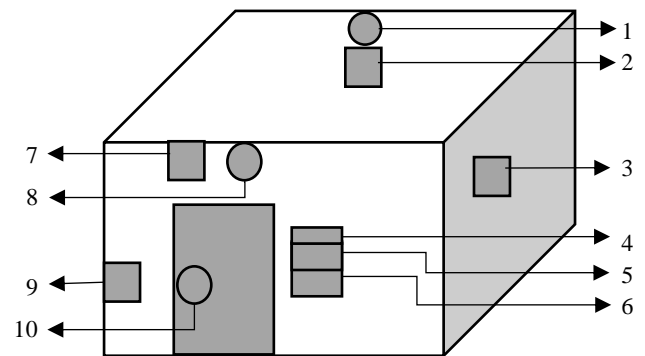

Fig. 4 Design of component placement in the server room

The following is a description of the names of all hardware components placed according to Fig. 4 in this study:

1. PIR1 sensor
2. Raspberry Pi and Pi Camera V2
3. DHT11 sensor
4. LCD 16x2
5. Keypad
6. RFID Reader
7. Buzzer
8. PIR2 sensor
9. Ultrasonic sensor
10. Solenoid Door Lock

### C. Simulation and Verification

At this stage, hardware and software simulations are carried out based on schematics and programs that have been made in the previous stage. Simulation is in the form of debugging this system program and verifying the circuit according to the schematic.

### D. Implementation

At this stage, all hardware and software are combined so that there is synchronization between the two things to suit the initial objectives of this research.

### E. Testing

At this stage, testing is carried out on the system created by testing the functionality of the tool based on commands sent from the telegram application and testing the system according to the scenario created.

## III. RESULTS AND DISCUSSION

The tests carried out in this study include 3 parts, namely testing the giving of commands to test the response of the tool,

testing when access rights are valid, and testing when an intruder tries to enter the server room.

#### A. Testing Commands

After all the parts of this tool are installed in the server room, the test command sent via the telegram application is carried out. This serves to ensure that the Raspberry Pi can read commands sent by users and the Raspberry Pi responds according to the commands given.

The initial command to start the bot is "/start". When receiving this command, the Raspberry Pi must respond by providing some information regarding how to use the bot command using this telegram application. The results of this test are shown in Fig. 5.

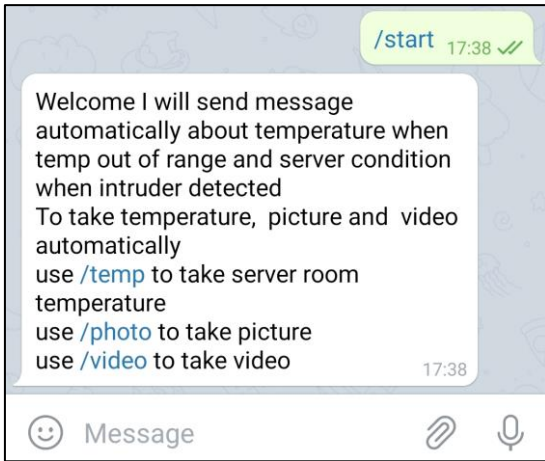

Fig. 5 Test "/start" command

The next test is testing every command that has been determined on the tool. The commands tested were the commands "/temp", "/photo" and "/video". Command "/temp" is used to get the measured temperature at that time. The command "/photo" is used to get a photo in the current server room. The command "/video" is used to get the video in the current server room. Each test on this command is performed 10 times.

When the user sends the "/temp" command, the Raspberry Pi will send the current measured temperature and humidity values 10 times. The test results for the "/temp" command are shown in Table 1.

TABLE I  
A COMMAND FOR ACTUAL TEMPERATURE AND HUMIDITY

Test No.	Command (Send)	Time (Send)	Response received	Time (Receive)
1.	/temp	17:38	√	17:38
2.	/temp	19:32	√	19:32
3.	/temp	20:11	√	20:11
4.	/temp	20:45	√	20:45
5.	/temp	21:10	√	21:10
6.	/temp	08:00	√	08:00
7.	/temp	08:30	√	08:30
8.	/temp	10:00	√	10:00
9.	/temp	12:15	√	12:15
10.	/temp	13:00	√	13:00

The time for testing the "/temp" command is varied, it is also intended to check that the tool is still running. From the test results in table 1, it can be seen that all the "/temp"

commands sent have been responded to well by the tool with a 100% success percentage from 10 testings.

The next test is testing the photo and video capture requests manually using the "/photo" and "/video" commands. The test results for this command are shown in Table 2.

TABLE II  
THE COMMAND FOR TAKING PICTURE MANUALLY

Test No.	Command (Send)	Time (Send)	Photo received	Time (Receive)
1.	/photo	15:35	√	15:35
2.	/photo	16:30	√	16:30
3.	/photo	18:20	√	18:20
4.	/photo	19:00	√	19:00
5.	/photo	20:50	√	20:50
6.	/photo	21:15	√	21:15
7.	/photo	07:40	√	07:40
8.	/photo	09:28	√	09:28
9.	/photo	10:18	√	10:18
10.	/photo	10:50	√	10:50

When the test is carried out regarding the "/photo" command, it is carried out in various ways, it is also intended to check that the tool is still working. From the test results in table 2, it can be seen that all the "/photo" commands sent have been responded to well by the tool with a 100% success percentage from 10 testings.

The next step is to test the video sending request command regarding the current server room situation using the "/video" command. The test results for the "/video" command that was performed are shown in Table 3.

TABLE III  
THE COMMAND FOR TAKING VIDEO MANUALLY

Test No.	Command (Send)	Time (Send)	Video received	Time (Receive)
1.	/video	16:45	√	16:46
2.	/video	17:05	√	17:05
3.	/video	18:00	√	18:01
4.	/video	18:20	√	18:20
5.	/video	19:15	√	19:15
6.	/video	21:00	√	21:01
7.	/video	08:36	√	08:36
8.	/video	09:10	√	09:11
9.	/video	10:15	√	10:16
10.	/video	12:05	√	12:05

The recording duration in this test is 15 seconds. The time for testing the "/video" command is varied, it is also intended to check that the tool is still working. From the test results in table 3, it can be seen that all "/video" commands sent have been responded to well by the tool with a 100% success percentage from 10 testings.

Testing of all commands that exist in this system has been successful 100% following every testing process that has been carried out.

#### B. Testing Regarding Valid Access

The next test is a test related to valid access. This test involves 3 users who have been given an RFID tag card with the test code names T1, T2, and T3. In this test, the user will "tap" the card to enter the server room. If the card is recognized, the door lock solenoid and all sensors are not active and Raspberry sends photos and videos to the admin.

In this testing process, testing was also carried out using an unrecognized RFID tag card with the card name "T4" (not registered in the system). The test results are shown in Table 4.

TABLE IV  
RFID TAG TESTING

Desc	RFID tag Recognized	Solenoid door lock	PIR 1	PIR 2	Ultra sonic	Photo and Video
T1	√	x	x	x	x	Sent
T2	√	x	x	x	x	Sent
T3	√	x	x	x	x	Sent
T4	x	√	√	√	√	No
T4	x	√	√	√	√	No
T2	√	x	x	x	x	Sent
T3	√	x	x	x	x	Sent
T4	x	√	√	√	√	No
T4	x	√	√	√	√	No
T1	√	x	x	x	x	Sent

From the test results shown in table 3 it can be explained that when the RFID card tag is recognized, the door lock solenoid will be deactivated so that the door can be opened. Furthermore, the PIR\_1 sensor, PIR\_2 sensor, and Ultrasonic sensor are also deactivated and the Raspberry Pi sends photos and videos when this happens. When the RFID tag is not recognized, the opposite happens where all actuators and sensors remain active. Of the 10 times, this testing process is all successful with a success percentage of 100%.

The next testing process is testing access to the server room using a password that is input via the 4x4 keypad. This test is performed 10 times by entering the passwords of 3 users. Recognized passwords are given the test code names P1, P2, and P3. The unknown passcode is given the test code name P4. The test results related to these access rights are shown in the Table 5.

TABLE V  
KEYPAD PASSWORD TESTING

Desc	Password Recognized	Solenoid door lock	PIR 1	PIR 2	Ultra sonic	Photo and Video
P3.	√	x	x	x	x	Sent
P4	x	√	√	√	√	No
P1	√	x	x	x	x	Sent
P2	√	x	x	x	x	Sent
P4	x	√	√	√	√	No
P1	√	x	x	x	x	Sent
P2	√	x	x	x	x	Sent
P4	x	√	√	√	√	No
P3	√	x	x	x	x	Sent
P1	√	x	x	x	x	Sent

The test results in table 5 show that when the input password is recognized, the door lock solenoid, PIR\_1 sensor, PIR\_2 sensor, and ultrasonic sensor will be deactivated. In other words, the user can enter the server room. At the same time, the Raspberry Pi will also take photos and videos then send them to the admin.

When the wrong password is entered, the actuator and all sensors remain active and the unauthorized person cannot enter the server room. Raspberry Pi also will not send photos

and videos at that time because indeed the server room is locked and no one is detected in the server room.

### C. Testing Regarding Invalid Temperature and Intruder Detection

The first test is a test related to temperatures that are outside the predetermined limits. Wherein in this system, the specified threshold is 21<sup>0</sup>C-23<sup>0</sup>C. The Raspberry Pi must send a message to the telegram bot when this happens. The test results in the form of a warning message received by the admin are shown in Fig. 6.

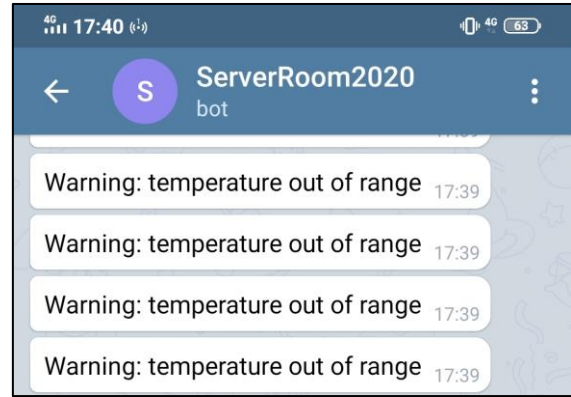

Fig. 6. Warning messages regarding temperature

The next test is testing when an intruder is detected entering from the front door. This means that an intruder breaks the front door to get into the server room. The distance read will automatically decrease. Furthermore, the Raspberry Pi will activate a warning buzzer and send a message to the telegram bot. Warning messages are sent in the form of text messages, photos, and videos. The message given by the system when this happens is shown in the Fig.7.



Fig. 7 Warning message regarding intruder from the front door

The next test is testing related to the PIR\_1 sensor and PIR\_2 sensor. This test aims to detect intruders who force their way through the roof or damage the back of the server room. When this happens, the intruder's movement will be detected by one or both of the PIR sensors. The message received by the user when an intruder is detected by the PIR\_1 sensor or the PIR\_2 sensor are shown in Fig. 8.



Fig. 8 Warning message regarding intruder detected with PIR sensor

Messages received by users are warning messages in the form of text, photos, and videos. After finishing sending all messages, the bot will wait for further instructions from the user. Commands can be in the form of commands to record and resend video or take photos. All these tests were successful and following the objectives and program scenarios.

Based on all test results, this tool has fulfilled the objective where this tool can monitor the condition and security of the server room by utilizing IoT technology, while in other studies it only focuses on temperature and humidity [5], [6], [8], and other studies only focus on door locks only [7].

#### IV. CONCLUSION

The server room can be monitored both for its condition and security by implementing IoT and utilizing the telegram API. This tool has been running well with a success

percentage of 100% following the tests carried out. With this tool, users can also maintain access to the server room and will immediately receive a warning via Telegram bot when something goes wrong in the server room. For further research development, it may be possible to add face detection features and the number of people in the server room.

#### REFERENCES

- [1] J. P. A. Yaacoub, O. Salman, H. N. Noura, N. Kaaniche, A. Chehab, and M. Malli, "Cyber-physical systems security: Limitations, issues and future trends," *Microprocess. Microsyst.*, vol. 77, pp. 1–45, Sep. 2020, doi: 10.1016/j.micpro.2020.103201.
- [2] I. Ghafir *et al.*, "Security threats to critical infrastructure: the human factor," *J. Supercomput.*, vol. 74, pp. 4986–5002, 2018, doi: 10.1007/s11227-018-2337-2.
- [3] N. Scarpato, A. Pieroni, L. Di Nunzio, and F. Fallucchi, "E-health-IoT universe: A review," *Int. J. Adv. Sci. Eng. Inf. Technol.*, vol. 7, no. 6, pp. 2328–2336, 2017, doi: 10.18517/ijaseit.7.6.4467.
- [4] Menteri Hukum Dan Hak Asasi Manusia, "Pedoman Penyelenggaraan Pusat Data Dan Ruang Server Di Lingkungan Kementerian Hukum Dan Hak Asasi Manusia Republik Indonesia," Indonesia, M.HH-01.TI.05.02, 2017. [Online]. Available: [https://www.kemendikham.go.id/attachments/article/1522/Keppm en Tentang Pedoman Penyelenggaraan Pusat Data dan Ruang Server - final.pdf](https://www.kemendikham.go.id/attachments/article/1522/Keppm%20tentang%20Pedoman%20Penyelenggaraan%20Pusat%20Data%20dan%20Ruang%20Server%20-%20final.pdf).
- [5] J. S. Jahlool, "Design and Simulation of Automatic Temperature Control and Alert System Based PIC16F887," *Int. J. Informatics Commun. Technol.*, vol. 6, no. 2, pp. 95–104, Aug. 2017, doi: 10.11591/ijict.v6i2.pp95-104.
- [6] S. A. u. R. Omer and E. Muhammad, "Design of intelligent air conditioner controller using fuzzy logic," in *2017 International Conference on Innovations in Electrical Engineering and Computational Technologies (ICIEECT)*, 2017, pp. 1–5, doi: 10.1109/ICIEECT.2017.7916556.
- [7] S. Niraj, K. Kamlesh, W. Pankaj, S. Danish, and G. Arvind, "Server Room Access Control Using Smartphone," *Int. J. Eng. Tech.*, vol. 4, no. 3, pp. 56–59, 2018, [Online]. Available: <http://www.ijetjournal.org>.
- [8] M. Alvan, P. Utomo, A. Aziz, and B. Harjito, "Server Room Temperature & Humidity Monitoring Based on Internet of Thing (IoT)," in *Journal of Physics: Conference Series*, 2019, pp. 1–8, doi: 10.1088/1742-6596/1306/1/012030.
- [9] J. Sobota, M. Goubej, J. Königsmarková, and M. Čech, "Raspberry Pi-based HIL simulators for control education," *IFAC-PapersOnLine*, vol. 52, no. 9, pp. 68–73, 2019, doi: <https://doi.org/10.1016/j.ifacol.2019.08.126>.
- [10] V. Chauhan, M. Patel, S. Tanwar, S. Tyagi, and N. Kumar, "IoT Enabled real-Time urban transport management system," *Comput. Electr. Eng.*, vol. 86, pp. 1–18, 2020, doi: <https://doi.org/10.1016/j.compeleceng.2020.106746>.
- [11] H. Hidayat, N. S. Hasibuan, and F. Wicaksono, "Design And Implementation Of Electronic Examination Device For Improving The Blind Students' Comfort," *J. Eng. Sci. Technol.*, vol. 16, no. 1, pp. 807–815, 2021, [Online]. Available: <https://jestec.taylors.edu.my/V16Issue1.htm>.
- [12] N. Bafdal and I. Ardiansah, "Application of Internet of Things in Smart Greenhouse Microclimate Management for Tomato Growth," *Int. J. Adv. Sci. Eng. Inf. Technol.*, vol. 11, no. 2, pp. 427–432, 2021, doi: 10.18517/ijaseit.11.2.13638.
- [13] T. Zou *et al.*, "Raspberry promotes brown and beige adipocyte development in mice fed high-fat diet through activation of AMP-activated protein kinase (AMPK)  $\alpha 1$ ," *J. Nutr. Biochem.*, vol. 55, pp. 157–164, 2018, doi: <https://doi.org/10.1016/j.jnutbio.2018.02.005>.
- [14] M. T. A. Seman, M. N. Abdullah, and M. K. Ishak, "Monitoring Temperature, Humidity And Controlling System In Industrial Fixed Room Storage Based On IoT," *J. Eng. Sci. Technol.*, vol. 15, no. 6, pp. 3588–3600, 2020, [Online]. Available: <https://jestec.taylors.edu.my/V15Issue6.htm>.
- [15] I. Ardiansah, N. Bafdal, E. Suryadi, and A. Bono, "Greenhouse monitoring and automation using arduino: A review on precision farming and Internet of Things (IoT)," *Int. J. Adv. Sci. Eng. Inf. Technol.*, vol. 10, no. 2, pp. 703–709, 2020, doi: 10.18517/ijaseit.10.2.10249.

- [16] M. Jacob and P. Mani, "A Reference Model For Testing Internet of Things Based Applications," *J. Eng. Sci. Technol.*, vol. 13, no. 8, pp. 2504–2519, 2018, [Online]. Available: <https://jestec.taylors.edu.my/V13Issue8.htm>.
- [17] S. Bin Saleh *et al.*, "Smart home security access system using field programmable gate arrays," *Indones. J. Electr. Eng. Comput. Sci.*, vol. 11, no. 1, pp. 152–160, 2018, doi: 10.11591/ijeecs.v11.i1.pp152-160.
- [18] M. Murad, O. Bayat, and H. M. Marhoon, "Design and implementation of a smart home system with two levels of security based on IoT technology," *Indones. J. Electr. Eng. Comput. Sci.*, vol. 21, no. 1, pp. 546–557, 2021, doi: 10.11591/ijeecs.v21.i1.pp546-557.
- [19] S. Nuanmeesri and L. Poomhira, "Optimization Shortest One-Way Path for Energy Saving Auto Robot Collecting Floating Garbage using Fast Approximate Nearest Neighbor Search," *Int. J. Adv. Sci. Eng. Inf. Technol.*, vol. 11, no. 2, pp. 457–464, 2021, doi: 10.18517/ijaseit.11.2.13191.
- [20] L. Benny and P. K. Soori, "Prototype of parking finder application for intelligent parking system," *Int. J. Adv. Sci. Eng. Inf. Technol.*, vol. 7, no. 4, pp. 1185–1190, 2017, doi: 10.18517/ijaseit.7.4.2326.
- [21] O. Appiah, E. Quayson, and E. Opoku, "Ultrasonic sensor based traffic information acquisition system; a cheaper alternative for ITS application in developing countries," *Sci. African*, vol. 9, p. e00487, 2020, doi: <https://doi.org/10.1016/j.sciaf.2020.e00487>.
- [22] X. Mouy *et al.*, "FishCam: A low-cost open source autonomous camera for aquatic research," *HardwareX*, vol. 8, p. e00110, 2020, doi: <https://doi.org/10.1016/j.ohx.2020.e00110>.
- [23] K. Miikki *et al.*, "An open-source camera system for experimental measurements," *SoftwareX*, vol. 14, p. 100688, 2021, doi: <https://doi.org/10.1016/j.softx.2021.100688>.
- [24] J. AnnRoseela and T. Godhvari, "Biometric and RFID based authentication system for exam paper leakages detection using IoT technology," *Indones. J. Electr. Eng. Comput. Sci.*, vol. 20, no. 3, pp. 1271–1277, 2020, doi: 10.11591/ijeecs.v20.i3.pp1271-1277.
- [25] M. El Beqqal, M. Azizi, and J. L. Lanet, "Multimodal access control system combining RFID, fingerprint and facial recognition," *Indones. J. Electr. Eng. Comput. Sci.*, vol. 20, no. 1, pp. 405–413, 2020, doi: 10.11591/ijeecs.v20.i1.pp405-413.
- [26] M. Vagaš, A. Galajdová, D. Šimšák, and D. Onofrejová, "Wireless data acquisition from automated workplaces based on RFID technology," *IFAC-PapersOnLine*, vol. 52, no. 27, pp. 299–304, 2019, doi: <https://doi.org/10.1016/j.ifacol.2019.12.677>.
- [27] M. K. Kah Wen, N. binti Ahmad, and S. H. binti Ruslan, "Arduino based outing and attendance system for boarding school students," *Indones. J. Electr. Eng. Comput. Sci.*, vol. 20, no. 2, pp. 1053–1061, 2020, doi: 10.11591/ijeecs.v20.i2.pp1053-1061.
- [28] N. Jannati, N. Nakhaee, V. Yazdi-Feyzabadi, and D. Tjondronegoro, "A cross-sectional online survey on patients' satisfaction using store-and-forward voice and text messaging teleconsultation service during the COVID-19 pandemic," *Int. J. Med. Inform.*, vol. 151, p. 104474, 2021, doi: <https://doi.org/10.1016/j.ijmedinf.2021.104474>.
- [29] A. Dargahi Nobari, M. H. K. M. Sarraf, M. Neshati, and F. Erfanian Daneshvar, "Characteristics of viral messages on Telegram; The world's largest hybrid public and private messenger," *Expert Syst. Appl.*, vol. 168, p. 114303, 2021, doi: <https://doi.org/10.1016/j.eswa.2020.114303>.

# LOG OJS

# International Journal on Advanced Science, Engineering and Information Technology

HOME ABOUT USER HOME SEARCH CURRENT ARCHIVES  
ANNOUNCEMENTS

Home > User > Author > Submissions > #13922 > Summary

## #13922 Summary

SUMMARY REVIEW EDITING

### Submission

Authors	Mochamad Fajar Wicaksono, Myrna Dwi Rahmatya, - Ilham
Title	IoT Implementation for Server Room Security Monitoring Using Telegram API
Original file	<a href="#">13922-30066-1-SM.DOC</a> 2020-12-08
Supp. files	None
Submitter	Mr. Mochamad Fajar Wicaksono
Date submitted	December 8, 2020 - 05:24 PM
Section	Articles
Editor	Rahmat Hidayat
Abstract Views	0

### Status

Status	Published Vol 12, No 5 (2022)
Initiated	2022-10-27
Last modified	2022-10-31

### Submission Metadata

#### Authors

Name	Mochamad Fajar Wicaksono
URL	<a href="https://www.scopus.com/authid/detail.uri?authorId=57204178999">https://www.scopus.com/authid/detail.uri?authorId=57204178999</a>
Affiliation	Computer Engineering Study Program, Universitas Komputer Indonesia, Bandung, Indonesia
Country	Indonesia
Bio Statement	Program Studi Teknik Komputer, Dosen.
Principal contact for editorial correspondence.	
Name	Myrna Dwi Rahmatya
URL	<a href="https://www.scopus.com/authid/detail.uri?authorId=57204184190">https://www.scopus.com/authid/detail.uri?authorId=57204184190</a>
Affiliation	Informatics Management Study Program, Universitas Komputer Indonesia, Bandung, Indonesia
Country	Indonesia
Bio Statement	Program Studi Manajemen Informatika, Dosen.
Name	- Ilham
Affiliation	Computer Systems Study Program, Universitas Komputer Indonesia, Bandung, Indonesia
Country	—
Bio Statement	Program Studi Teknik Komputer.

#### Title and Abstract

Title	IoT Implementation for Server Room Security Monitoring Using Telegram API
Abstract	This research aims to create a system that can monitor server room security by utilizing IoT technology, controllers, sensors, actuators, and Telegram API. The system made includes security for the indoor and outdoor parts. The method used in this study is experimental. The output obtained by the user is telegram text messages, photos, and video. The main controller on this system is the Raspberry Pi. This study showed that if the server room temperature is >230C, the system will send a message via Telegram. If the PIR sensor_1 or PIR sensor_2 detects an intruder or the measured distance is <300cm from the side of the door, the system will send text messages, photos, and videos via Telegram. That way, the user can determine the next steps related to the condition of the server room. However, if the RFID tag is recognized, the solenoid door lock, PIR, and ultrasonic will be deactivated. Other features, Users can ask the system to record a video of the room conditions and also messages related to room temperature through commands sent via Telegram messages. Testing is carried out using 3 scenarios: testing command, testing regarding valid access, and testing regarding invalid



temperature and intruder detection. Overall test results show all these tests were successful 100% and followed the objectives and program scenarios. This tool has fulfilled the objective where this tool can monitor the condition and security of the server room by utilizing IoT technology.

## Indexing

Keywords IoT; server room; monitoring; Raspberry Pi; Telegram.  
Language en

## Supporting Agencies

Agencies —

## References

- References
- J. P. A. Yaacoub, O. Salman, H. N. Noura, N. Kaaniche, A. Chehab, and M. Malli, "Cyber-physical systems security: Limitations, issues and future trends," *Microprocess. Microsyst.*, vol. 77, pp. 1–45, Sep. 2020, doi: 10.1016/j.micpro.2020.103201.
- I. Ghafir et al., "Security threats to critical infrastructure: the human factor," *J. Supercomput.*, vol. 74, pp. 4986–5002, 2018, doi: 10.1007/s11227-018-2337-2.
- N. Scarpato, A. Pieroni, L. Di Nunzio, and F. Fallucchi, "E-health-IoT universe: A review," *Int. J. Adv. Sci. Eng. Inf. Technol.*, vol. 7, no. 6, pp. 2328–2336, 2017, doi: 10.18517/ijaseit.7.6.4467.
- Menteri Hukum Dan Hak Asasi Manusia, "Pedoman Penyelenggaraan Pusat Data Dan Ruang Server Di Lingkungan Kementerian Hukum Dan Hak Asasi Manusia Republik Indonesia," Indonesia, M.HH-01.TI.05.02, 2017. [Online]. Available: [https://www.kemenkumham.go.id/attachments/article/1522/Kepmen Tentang Pedoman Penyelenggaraan Pusat Data dan Ruang Server - final.pdf](https://www.kemenkumham.go.id/attachments/article/1522/Kepmen%20Tentang%20Pedoman%20Penyelenggaraan%20Pusat%20Data%20dan%20Ruang%20Server%20-%20final.pdf).
- J. S. Jahlool, "Design and Simulation of Automatic Temperature Control and Alert System Based PIC16F887," *Int. J. Informatics Commun. Technol.*, vol. 6, no. 2, pp. 95–104, Aug. 2017, doi: 10.11591/ijict.v6i2.pp95-104.
- S. A. u. R. Omer and E. Muhammad, "Design of intelligent air conditioner controller using fuzzy logic," in *2017 International Conference on Innovations in Electrical Engineering and Computational Technologies (ICIEECT)*, 2017, pp. 1–5, doi: 10.1109/ICIEECT.2017.7916556.
- S. Niraj, K. Kamlesh, W. Pankaj, S. Danish, and G. Arvind, "Server Room Access Control Using Smartphone," *Int. J. Eng. Tech.*, vol. 4, no. 3, pp. 56–59, 2018, [Online]. Available: <http://www.ijetjournal.org>.
- M. Alvan, P. Utomo, A. Aziz, and B. Harjito, "Server Room Temperature & Humidity Monitoring Based on Internet of Thing (IoT)," in *Journal of Physics: Conference Series*, 2019, pp. 1–8, doi: 10.1088/1742-6596/1306/1/012030.
- J. Sobota, M. Goubelj, J. Königsmarková, and M. Čech, "Raspberry Pi-based HIL simulators for control education," *IFAC-PapersOnLine*, vol. 52, no. 9, pp. 68–73, 2019, doi: <https://doi.org/10.1016/j.ifacol.2019.08.126>.
- V. Chauhan, M. Patel, S. Tanwar, S. Tyagi, and N. Kumar, "IoT Enabled real-Time urban transport management system," *Comput. Electr. Eng.*, vol. 86, pp. 1–18, 2020, doi: <https://doi.org/10.1016/j.compeleceng.2020.106746>.
- H. Hidayat, N. S. Hasibuan, and F. Wicaksono, "Design And Implementation Of Electronic Examination Device For Improving The Blind Students' Comfort," *J. Eng. Sci. Technol.*, vol. 16, no. 1, pp. 807–815, 2021.
- N. Bafdal and I. Ardiansah, "Application of Internet of Things in Smart Greenhouse Microclimate Management for Tomato Growth," *Int. J. Adv. Sci. Eng. Inf. Technol.*, vol. 11, no. 2, pp. 427–432, 2021, doi: 10.18517/ijaseit.11.2.13638.
- T. Zou et al., "Raspberry promotes brown and beige adipocyte development in mice fed high-fat diet through activation of AMP-activated protein kinase (AMPK)  $\alpha 1$ ," *J. Nutr. Biochem.*, vol. 55, pp. 157–164, 2018, doi: <https://doi.org/10.1016/j.jnutbio.2018.02.005>.
- M. T. A. Seman, M. N. Abdullah, and M. K. Ishak, "Monitoring Temperature, Humidity And Controlling System In Industrial Fixed Room Storage Based On IoT," *J. Eng. Sci. Technol.*, vol. 15, no. 6, pp. 3588–3600, 2020.
- I. Ardiansah, N. Bafdal, E. Suryadi, and A. Bono, "Greenhouse monitoring and automation using arduino: A review on precision farming and Internet of Things (IoT)," *Int. J. Adv. Sci. Eng. Inf. Technol.*, vol. 10, no. 2, pp. 703–709, 2020, doi: 10.18517/ijaseit.10.2.10249.
- M. Jacob and P. Mani, "A Reference Model For Testing Internet of Things Based Applications," *J. Eng. Sci. Technol.*, vol. 13, no. 8, pp. 2504–2519, 2018.
- S. Bin Saleh et al., "Smart home security access system using field programmable gate arrays," *Indones. J. Electr. Eng. Comput. Sci.*, vol. 11, no. 1, pp. 152–160, 2018, doi: 10.11591/ijeecs.v11.i1.pp152-160.
- M. Murad, O. Bayat, and H. M. Marhoon, "Design and implementation of a smart home system with two levels of security based on IoT technology," *Indones. J. Electr. Eng. Comput. Sci.*, vol. 21, no. 1, pp. 546–557, 2021, doi: 10.11591/ijeecs.v21.i1.pp546-557.
- S. Nuanmeesri and L. Poomhiran, "Optimization Shortest One-Way Path for Energy Saving Auto Robot Collecting Floating Garbage using Fast Approximate Nearest Neighbor Search," *Int. J. Adv. Sci. Eng. Inf. Technol.*, vol. 11, no. 2, pp. 457–464,

2021, doi: 10.18517/ijaseit.11.2.13191.

L. Benny and P. K. Soori, "Prototype of parking finder application for intelligent parking system," *Int. J. Adv. Sci. Eng. Inf. Technol.*, vol. 7, no. 4, pp. 1185–1190, 2017, doi: 10.18517/ijaseit.7.4.2326.

O. Appiah, E. Quayson, and E. Opoku, "Ultrasonic sensor based traffic information acquisition system; a cheaper alternative for ITS application in developing countries," *Sci. African*, vol. 9, p. e00487, 2020, doi: <https://doi.org/10.1016/j.sciaf.2020.e00487>.

X. Mouy et al., "FishCam: A low-cost open source autonomous camera for aquatic research," *HardwareX*, vol. 8, p. e00110, 2020, doi: <https://doi.org/10.1016/j.ohx.2020.e00110>.

K. Miiikki et al., "An open-source camera system for experimental measurements," *SoftwareX*, vol. 14, p. 100688, 2021, doi: <https://doi.org/10.1016/j.softx.2021.100688>.

J. AnnRoseela and T. Godhavari, "Biometric and RFID based authentication system for exam paper leakages detection using IoT technology," *Indones. J. Electr. Eng. Comput. Sci.*, vol. 20, no. 3, pp. 1271–1277, 2020, doi: 10.11591/ijeecs.v20.i3.pp1271-1277.

M. El Beqqal, M. Azizi, and J. L. Lanet, "Multimodal access control system combining RFID, fingerprint and facial recognition," *Indones. J. Electr. Eng. Comput. Sci.*, vol. 20, no. 1, pp. 405–413, 2020, doi: 10.11591/ijeecs.v20.i1.pp405-413.

M. Vagaš, A. Galajdová, D. Šimšík, and D. Onofrejová, "Wireless data acquisition from automated workplaces based on RFID technology," *IFAC-PapersOnLine*, vol. 52, no. 27, pp. 299–304, 2019, doi: <https://doi.org/10.1016/j.ifacol.2019.12.677>.

M. K. Kah Wen, N. binti Ahmad, and S. H. binti Ruslan, "Arduino based outing and attendance system for boarding school students," *Indones. J. Electr. Eng. Comput. Sci.*, vol. 20, no. 2, pp. 1053–1061, 2020, doi: 10.11591/ijeecs.v20.i2.pp1053-1061.

N. Jannati, N. Nakhaee, V. Yazdi-Feyzabadi, and D. Tjondronegoro, "A cross-sectional online survey on patients' satisfaction using store-and-forward voice and text messaging teleconsultation service during the COVID-19 pandemic," *Int. J. Med. Inform.*, vol. 151, p. 104474, 2021, doi: <https://doi.org/10.1016/j.ijmedinf.2021.104474>.

A. Dargahi Nobari, M. H. K. M. Sarraf, M. Neshati, and F. Erfanian Daneshvar, "Characteristics of viral messages on Telegram; The world's largest hybrid public and private messenger," *Expert Syst. Appl.*, vol. 168, p. 114303, 2021, doi: <https://doi.org/10.1016/j.eswa.2020.114303>.

# International Journal on Advanced Science, Engineering and Information Technology



HOME ABOUT USER HOME SEARCH CURRENT ARCHIVES  
ANNOUNCEMENTS

Home > User > Author > Submissions > #13922 > Review

## #13922 Review

SUMMARY **REVIEW** EDITING

### Submission

Authors Mochamad Fajar Wicaksono, Myrna Dwi Rahmatya, - Ilham   
 Title IoT Implementation for Server Room Security Monitoring Using Telegram API  
 Section Articles  
 Editor Rahmat Hidayat 

### PeerReview



#### Round 1

Review Version [13922-30067-1-RV.DOC](#) 2020-12-08  
 Initiated 2021-03-02  
 Last modified 2021-06-11  
 Uploaded file None  
 Editor Version None  
 Author Version [13922-34707-1-ED.DOCX](#) 2021-06-19

#### Round 2

Review Version [13922-30067-2-RV.DOCX](#) 2021-06-22  
 Initiated 2021-06-22  
 Last modified 2021-06-28  
 Uploaded file None

### Editor Decision

Decision Accept Submission 2021-07-05  
 Notify Editor  Editor/Author Email Record  2021-07-05  
 Editor Version None  
 Author Version [13922-34707-2-ED.DOCX](#) 2022-09-21 [DELETE](#)  
 Upload Author Version  No file chosen

Published by INSIGHT - Indonesian Society for Knowledge and Human Development