

BUKTI KORESPONDENSI
ARTIKEL JURNAL INTERNASIONAL

Judul Artikel : What Determine Accounting information System Implementation? Evidence From Indonesia
Jurnal : Finance, Accounting and Business Analysis (FABA), Vol. 2 No. 2 (2020)
Penulis : Penulis Mandiri

No.	Perihal	Tanggal
1.	Bukti konfirmasi submit artikel dan artikel yang disubmit	23 Jan 2020
2.	Bukti konfirmasi review dan hasil review pertama	
3.	Bukti konfirmasi submit revisi pertama, respon kepada reviewer, dan artikel yang diresubmit	4 Maret 2020
4.	Bukti konfirmasi review dan hasil review kedua	
5.	Bukti konfirmasi submit revisi kedua, respon kepada reviewer, dan artikel yang diresubmit	
6.	Bukti konfirmasi artikel accepted	17 Mei 2020
7.	Bukti konfirmasi artikel published online	7 September 2020

[HOME](#) / [Submissions](#)

[Make a new submission](#) or [view your pending submissions](#).

Submission Preparation Checklist

As part of the submission process, authors are required to check off their submission's compliance with all of the following items, and submissions may be returned to authors that do not adhere to these guidelines.

- The submission has not been previously published, nor is it before another journal for consideration (or an announcement has been provided in Comments to the Editor)

[Focus & Scope](#)

[Ethics Statement](#)

[Abstracting/Indexing](#)

[Editorial Board](#)

[Peer Review Process](#)

[Instructions for Authors](#)

[Online Submission Here](#)

[Policy of Screening](#)

[Author Fees](#)

[Open Access Policy](#)

[Copyright Notice](#)

[Contact Us](#)

[HOME](#) / [ARCHIVES](#) / [VOL 2 NO 2 \(2020\)](#) / [Articles](#)

What Determine Accounting information System Implementation? Evidence From Indonesia

Sri Dewi Anggadini

Universitas Komputer Indonesia, Indonesia

DOI: <https://doi.org/10.16408/faba.v2i2.42>

 [PDF](#)

PUBLISHED

2020-07-09

[Focus & Scope](#)

[Ethics Statement](#)

[Abstracting/Indexing](#)

[Editorial Board](#)

[Peer Review Process](#)

[Instructions for Authors](#)

[Online Submission Here](#)

[Policy of Screening](#)

[Author Fees](#)

[Open Access Policy](#)

[Copyright Notice](#)

[Contact Us](#)

What Determine Accounting information System Implementation? Evidence From Indonesia

Sri Dewi Anggadini

Accounting Department, Universitas Komputer Indonesia, Indonesia

Info Articles

History Article:
Submitted 23 January 2020
Revised 4 March 2020
Accepted 17 May 2020

Keywords:
Accounting information System,
Accounting information, Ethic
and Competence

Abstract

This study is about how the implementation of accounting information systems produces quality of financial information on State Owner Enterprises in Indonesia. This study answers the problem of how the accounting information system produces accurate, relevant, timely and complete financial information. The implementation of the accounting information system, can not be separated from ethics and user competence as a factor that has an impact on the current accounting information system. Data was collected using questionnaires, direct observation, and interviews. The research method used is quantitative and qualitative with a descriptive and verification approach. The number of samples used were 58 State Owner Enterprises Indonesia. The analytical tool in the study uses path analysis by testing the SPSS hypothesis. The results of the study show that ethics and user competence affect the implementation of accounting information systems and also affect the quality of financial information.

Address Correspondence:
E-mail: sri.dewi@email.unikom.ac.id

INTRODUCTION

In an organization, especially private organizations, the accuracy and completeness of information information in this case finance becomes the main element in its management so as to achieve optimal company goals. Quality of financial information is not possible if the accounting information system implemented is not in accordance with the rules. Many problems occur because accounting information is not presented accurately, timely, relevant and complete so that it is easy to abuse. In the information system that is available, not everyone is satisfied with the information system based on the case experienced by PT Kereta Api Indonesia when implementing the ERP (Enterprise Resource Planning) system that is used has failed due to errors in the IT team. The difficult situation experienced by the Information Technology Team in managing human resources and infrastructure in the form of fostering a sense of leadership and employee confidence that in its management has targets whose achievements require no short time, besides producing a level of satisfaction that is not yet optimal, the information system used by PT Kereta Api Indonesia (Persero) has not yet been integrated, in the sense each organizational function and subdivision works separately.

Users of information systems who are dissatisfied have been felt by users of information systems at PT Pos (Persero). Before PT Pos (Persero) replaced the accounting information network system to ERP with a SAP based tool that is now in operation after it only began operating in January 2013, the performance of PT Pos Indonesia before the replacement of the system was considered to be very slow. Another phenomenon occurs in PLN workers who are members of the PLN Workers Union (SP) in Sumatra that is not in accordance with the new system that has been implemented, namely the change of the manual payment system to an online system. During this salary payment system, bonuses especially SPPD (Official Travel Order) is done manually through approval through a piece of paper, but since the ERP was launched on July 1, 2012 the payment system, especially SPPD (Official Travel Order) changed to the online system. From the above phenomenon implies that the process is too long to delay the SPPD payment due to the use of an online payment system that makes PT PLN employees feel disadvantaged, this does not reflect indicators of the quality of financial information, one of which is the satisfaction of users of the IS measured by using questionnaires and interviews.

This condition requires the improvement of the AIS of each institution in the government and strengthens the synergized accounting information system owing to the fact that through the application of a quality AIS, it is expected to realize the goals of the organization (Gelinas et al., 2012). One of the ways by companies to detect errors and minimize the risk of errors is to facilitate the implementation of AIS. In contrast to previous studies this study explains detecting fraudulent in terms of the application of AIS (Bassellier, 2000). This research is important to do, because it can identify fraud in State Owner Enterprises throughout Indonesia, this research can find out implementation of accounting information systems (Sri Dewi Anggadini, 2018)

Such problems that occur the discussion of the accounting information system are associated with the influencing factors in the form of ethics and competencies that occur in State Owner Enterprises throughout Indonesia.

LITERATURE REVIEW

User Ethic

Users of information systems in an organization are very important in producing information that will significantly contribute to strategic running and achieving competitive advantage (McLeod & Schell, 2007: 79). Bodnar & Hopwood (2014: 158) added that users consist of heterogeneous groups of people and can be distinguished from others because they are based on functions related to data processing or information technology. Ethics appears in someone who has a valuable character in every step of decision making. Honest, fair, responsibility and empathy are values for someone who is ethical. (Horngren et al., 2008: 25). Agree with Hansen & Mowen (2007: 17) and Horngren et al (2008: 25), Hartman & Desjardins (2008: 76) revealed that the ethical characteristics applied in carrying out activities consisted of honesty, quality, responsibility, compassion, fairness and respect. Based on the description above, the dimensions and indicators of user ethics used in this study refer to the theory according to Laudon & Laudon (2014: 159), supported by the theory presented by Hansen & Mowen (2007: 17).

User Competency

High personal competence will spur users to use AIS, so that the quality of AIS becomes more effective. Users of information systems who have good techniques derived from education that have been taken or from experience using the system will increase satisfaction in using the accounting information system. The definition of competence proposed by Dessler (2011: 169) is Competencies is a personality

that a person shows for the performance he produces. Work based on competence shows that the work done can be measured, observed and proven both from knowledge, skills and behavior that shows good behavior in accordance with the expected job criteria. Furthermore Mondy (2010: 244) states Competence has an element of ability and variety of all skills possessed by someone both related to technical, character or orientation to the future. The sustainability of the information system is inseparable from the user who runs the organizational function in this case the information system (Bodnar & Hopwood, 2014: 17). As a user, an accountant must be able to be involved in designing accounting information systems (Gelinias et al., 2012: 27) so that competence is needed from users in the implementation of information systems (Kassboll & Chawani, 2010) because user competency is an important element in determining an information system can be implemented optimally.

Accounting information System Implementation

AIS is one type of system needed by companies to produce financial information needed by personnel and other related parties in connection with decision making and other policies. In general, all companies need reliable, timely and accurate information. The fundamental role of AIS in organizations is to produce quality of financial information (Azhar Susanto, 2008: 374). In addition, the implementation of information system is the key for an organization to achieve success effectively (Wixom, 2005). System quality is one set of characteristics will be fairly apparent to users after they have interact with the system for only a short period time. Gorla et al. (2010) states that the implementation of information system is measured from technically sound, error-free, easy to learn, user friendly, well documented and flexible (Kouser, 2011). Furthermore O'Brien & Marakas (2011: 51) states the success of information systems is not only measured in terms of efficiency, in this case the minimal cost, time of information resources used, but success is also measured through the effectiveness of information technology that supports the organization's business strategy. Gelderman (1998), the successful application of AIS is the intensity of the use of AIS (intended use) in daily work and user satisfaction. Whereas Gorla et al. (2010) measure the quality of the system seen from error free, easy to learn, easy to use, good documentation and flexible.

Financial Information Quality

O'Brien & Marakas (2011: 424) argues that quality of information if the information product that has valuable and accountable characteristics, attributes and content so that information can be used as a basis for decision making. Information has three dimensions, namely time, content and form. According to Kieso et al. (2012: 44) information quality is measured by relevance, faithful representation and enhancing qualities. Whereas McLeod & Schell (2007: 35) and Azhar Susanto (2008: 13) state that a quality information must have characteristics of relevance, accuracy, timeliness and completeness. Then Hall (2011: 13) adds summarizing so that the measurement of quality accounting information consists of relevance, accuracy, timeliness, completeness and summarizing. Alter (2002: 67) states that quality information can be measured by accuracy, precision, completeness, age, timeliness and the source of the information. Not much different according to McManus & Harper (2003: 257) the basic key in determining quality information is seen from functionally, reliability, efficiency, usability, portability and maintainability. Next Romney & Steinbart (2015: 30) determine the information quality have some the characteristics. In line with Schermerhorn (2011: 159) criteria for quality information consists of timely, high quality, complete, relevant and understandable.

Theoretical Framework

Ethical linkages with information systems conveyed by Hall (2011: 112) that ethics is closely related to business, information systems and computer technology. This was confirmed by Henderson et al (2006: 314) that the application of accounting information systems is inseparable from user ethics such as conditions for illegally copying information, misuse of information, computer crime, information fraud. The results of the Myers & Venable (2014) study concluded that there are 6 (six) ethical principles that must be applied in the use of IS. The public interest is meant to prioritize the public interest over personal interests, informed consent shows that in carrying out activities related to running an IS, it is necessary to pay attention to the rights and risks received, privacy is to maintain and respect each other, honesty and accuracy is the ethics of actually carrying out activities, property What is meant is an agreement on ownership of information, quality of the artifact. Furthermore Olumoye (2013) in his research revealed that ethics in this case the responsibility and accountability of a person is needed in carrying out their activities in the context of developing information systems. This is in agreement with Chen, et al (2011) in his research that user responsibility has an important role in improving the performance of information systems. Guragai et al. (2014) in his research revealed the relationship between SIA and ethics that need to be considered if there is a gap to provide input for further research. Ethics deals with the main function of SIA, which is recording, reporting, and control, with a focus on data and the use of SIA as needed

Kreitner & Kinicki (2010: 137) states that the concept of competence is understood as a combination of ability and skills because both of them receive considerable attention in today's management circles. The efficient and effective use of this information system requires workers who have the necessary knowledge and skills (Henderson, 2006: 5). McLeod & Schell (2007: 76) states that user knowledge and skills are needed in the use and utilization of information systems. Munirath et al. (2014) state that the knowledge and skills of information technology and the ability to regulate the information system processes in an organization are the main factors that have an impact on IS quality. Sabherwal et al. (2006) in his research stated experience of one measure of competence that affects the implementation of IS that are applied. The experience of IS has a positive effect on the implementation of information systems. This finding means that the more user experience about information systems, the implementation of IS will be aligned. Next Bassellier et al. (2000) in his research revealed the dimensions of competence can be in the form of psychology, education, self-management, human resources including knowledge and skills have an impact on the success of IS.

Research directed to the influence of the quality of SIA on the quality of financial information empirically shows the following results: Salehi et al (2010), on the success of IS in the emergence of the economy in Iran, shows the results that AIS can improve the truth of financial statements and finance report. A study conducted by Sajady et al (2008) on evaluating the effectiveness of accounting information systems also shows the results that the implementation of accounting information systems in companies can cause improvements in the quality of financial statements and accelerate the company's transaction process. Then research conducted by x and Pilar (2000) on improving accounting information systems through the integrity of new technologies shows results consistent with the two previous researchers, that accounting information systems can be considered as a support base for satisfying information requests during the decision making process. In the case of this research, it is stated about the characteristics that must be possessed by the accounting information system in the operational phase in an effort to increase the quantity and quality of information. To reinforce the study of the influence of accounting information system quality on the quality of financial information, Xu (2009) in their case study in Australia, related to key issues of management of financial information quality concludes also that issues related to AIS are seen as the most critical of high quality information.

Based on the aforementioned framework, the hypotheses proposed in this study are:

- H1 : User ethics affect the quality of AIS
- H2 : User competence affects the quality of AIS
- H3 : The quality of AIS influences the quality of financial information.

METHODS

The method used is verification (verificative research) and explanatory (explanatory research) or causality (causal study), that this research aims to determine that one variable causes changes to another. In order to facilitate the interpretation and testing of hypotheses, the data collected will be analyzed using certain methods. The data of this study were obtained by submitting the questionnaire to the respondents through a questionnaire, the answers from the respondents to the question were the measures to be tested. In the data obtained from the respondents tested the validity and reliability so that the data can accurately describe the measured concept. Because the data of research variables obtained through questionnaires are data with ordinal scale, so that data can be analyzed statistically the scale must be scaled into intervals using the Method of Successive Interval (MSI). n analyzing the data of this study using path analysis which aims to determine the cause and effect between independent and dependent variables so that by using this path analysis the magnitude of the influence of each independent variable on the dependent variable. Based on the relationship between exogenous variables (X), a path diagram can be drawn that describes the relationship paradigm between variables as shown in the following figure:

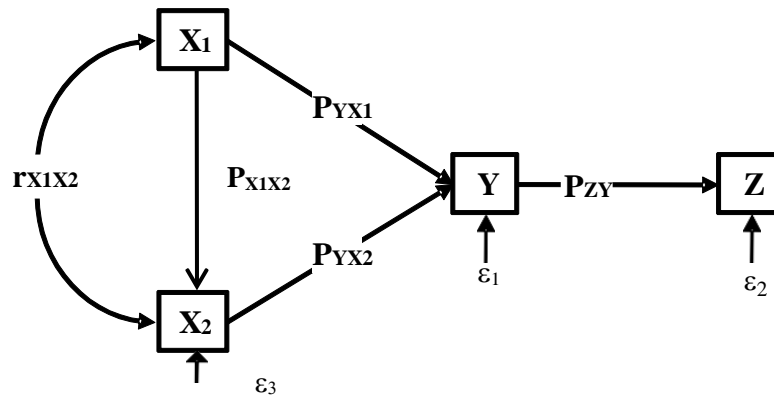

Figure 1. Path Analysis Structure

Hypothesis testing is done using path analysis. Path diagram as shown in figure 1 above can be formulated into 2 structural equation forms as follows:

Description:

AIS= Implementation of AIS

E = Ethics

C = Competence

AI = Financial Information

RESULTS AND DISCUSSION

The statement of the questionnaire submitted must meet the standards of valid and reliabel. Validity and reliability tests show that the statements in this study using co-efficiency correlation not less than 0.30 and the recommended co-efficiency reliability is not less than 0.70. The measurement tool used to analyze validity and reliability is the SPSS version 20 program.

Table 1. Recapitulation of Valid and Reliabel

Item	R	Valid	Reliabel
Ethics	0.445-0.671	Valid	0.7001
Competence	0.404-0.615	Valid	0.7668
AIS	0.600-0.713	Valid	0.7865
Accounting information	0.551-0.750	Valid	0.7432

The accuracy of the respondent's answers is very important so that it will have an impact on the validity and reliability test. Variable descriptive analysis in this study includes user ethics, user competence, implementation of accounting information systems, and quality of financial information. To describe the variables, in this study using the percentage of the actual score of each dimension of the ideal score, then the data is interpreted into five categories, among others: superior, good, sufficient, moderate, and worst. Variables are measured using rankings summarized from Likert. The score is given in the answers which are then summed up. The score summary table is presented as percentage values and categories of each variable.

Judging calculation, it shows that the respondent's statement about the user's ethics can be considered fair with a score of 64.7%. This means that user ethics carried out in State Owner Enterprises can be considered fair. Furthermore, related to user competence, respondents stated that it was identified as fair with a score of 64.9%. This means that the user's competence has an impact on the activities that have been carried out. The same measurement can be reflected in the AIS that is run. The system is showed fair with a value of 57.8% even though the respondent gave a bad answer with a score of 50.6%. This phenomenon illustrates that the accounting information system applied in State-Owned Enterprises runs fairly, but still has shortcomings in its implementation. Furthermore, quality AI, in general, is considered fair with a score of 60.9% but has a lack of accuracy; accounting information has been reported on time, has 50.4%.

To analyze user ethics and user competency in the current accounting information system and influence quality AI, this research uses path analysis method. However, before analyzing the causal pathway, a significant test is needed for each path coefficient. The measurement scale of both cause and

effect variables must include interval size, so it is necessary to increase the measurement scale from ordinal to interval using the MSI method. The following table 2 shows the results linking the Y variable and the Z variable.

Table 2. Kol-Smirnov

		Y	Z
N		58	58
Interval Normal	Mean	92.74523157	6689014
	Standar	22.58591	13.51865
Most Extreme	Abs	.185	.256
	Between	+	.156
		-	.178
Kolmogorof		.985	1.457
	2-tailed	.568	.086

In table 2 it can be explained about significant value to test the normality of the Y variable is 0.568 and the Z variable is 0.086. These values are greater than 0.05 so that it can be said that the data stated in the variables Y and Z are normally distributed. The model in this study has the following two sub-structures :

AIS= Implementation of AIS
 E = Ethics
 C = Competence
 AI = Financial Information

Model: Sub structure 1: $Y = P_{yx1} X_1 + P_{yx2} X_2 + \square_1$

SPSS used in this study, obtained the path coefficient value to determine P_{yx1} value of 0.546 and P_{yx2} of 0.372. The following table shows the R2 value, namely the number of simultan impact (together) of the independent variables on dependent Y.

Table 3. Model Summary

Item	R	Square	R2	Error	Str
1	.876 ^a	.872	.864	.3122	

Predictors : (constant), X_2 , X_1

Based on this table illustrates about $R^2 = 0.872$ of adjusted $R^2 = 0.864$. Conditions means about the two variables, User Ethics and User Competency - have an simultaneous effect (together) on the implementation of AIS as much as 87.2%. Next, this conditions value of 12.8% or more than 0.128 represents the influence of another object not examined.

Sub structure 1: $Y = 0.546 X_1 + 0.372 X_2 + 0.872$

Next, simultaneous hypothesis the variables

Table 4. Simultaneous

F Test

F_{count}	F_{table}	p-value	Item
46.174	2.8571	0.000	count > table

This tables illustrates about F count value is 46,174. This value will be tested using statistics and then compared with other F values in the table for $\alpha = 0.05$. It is learned that the F table value is 2.8571 achieved because the F count value is greater than F table. The results showed that the level of deficiency was 5% ($\alpha = 0.05$), so H_0 was rejected and H_1 was accepted. In this case, it can be concluded that, with a confidence level reaching 95%, user ethics and user competence have a significant influence on the implementation of accounting information systems in State Owner Enterprises throughout Indonesia.

Table 5. Partial

t count	t tabel	p-value
4.381	1.7542	0.018

2.756 1.7542 0.034

Table 6. Conclusion			
T Test			
t count	t tabel	p-value	Item
4.381	1.7542	0.018	count > table
2.756	1.7542	0.034	count > table

This table above, both each independent variable shows significant results. This illustrates that both the user's ethical variables and the user's competencies have a significant effect on the information system run by the company. In other words, these two variables are important factors that must be considered in running the system Model : Sub structure 2 : $Z = P_{zy} Y + \square_2$
 Based on this description, can described dan explain in figure 2.

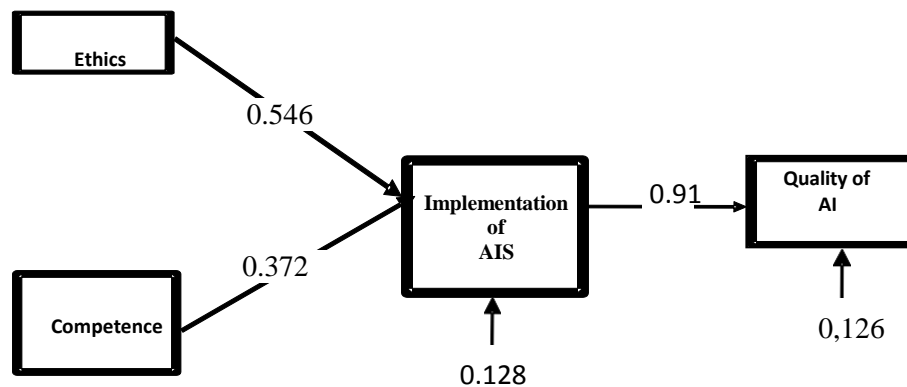

Figure 1. The Result of Research Model Path Diagram

Effect User Ethic on AIS Quality

The results of testing the data states that user ethics affect the quality of AIS, but the implementation is not optimal enough to improve the quality of AIS. Therefore, to improve the quality of AIS that exist in SOEs, the user ethics must also be improved. Rocheleau (2006: 264) who revealed that ethics related to the information system environment. Next, continued O'Brien & Marakas (2011: 54) asserting that as managers, professional entrepreneurs and employees must have ethical responsibilities in the use of information systems. Still according to O'Brien & Marakas (2011: 562) that ethics can not be separated from the use of information systems, which in their use in business, have a large impact on society and thus can cause ethical problems in the areas of crime, privacy, individuality, work, health and working conditions. Ethical linkages with information systems conveyed by Hall (2011: 112) that ethics is closely related to business, information systems and computer technology. This was confirmed by Simkin et al (2013: 314) that the application of AIS is inseparable from user ethics such as conditions for illegally copying information, misuse of information, computer crime, information fraud.

Effect User Competency on AIS Quality

The results of testing the influence of user competencies on the quality of financial information systems indicate that user competencies affect the quality of AIS. The discussion of this study provide empirical evidence that the better the competency of users will improve the quality of AIS. In other words it can be interpreted that the quality of AIS can be improved if SOEs increase user competency by providing human resources such as managers or staff who have knowledge and skills. This is in accordance with Laudon & Laudon (2014: 114) states that in order to implement a successful or quality information system, managers or staff as users must have skills related to information systems. Daoud & Triki (2013) revealed in his research that the competency of accounting users is an important factor in the success of AIS. The same thing was conveyed by Taher Belhaj et al. (2014) in his research that the success of IS is highly dependent on the level of competency of its users.

Effect AIS Quality on Financial Information Quality

The results of the study are also in line with the opinion of Hall (2007: 21) which states that the accounting information system supports the provision of accounting information. This result also supports the opinion of O'Brien & Marakas (2011: 34), that the purpose of an information system is to produce

enough information for its users (Ahmad, 2013). This is also in line with research, such as research conducted by Taher Belhaj et al. (2014) which states that the quality of AIS affects the quality of financial statements (Alzoubi, Ali. 2011). This result is also in line with Xu (2009) who found a significant impact of the quality of AIS on accounting information (Sri Dewi Anggadini, 2017). The results of data testing also support the research of Salehi et al (2010) which states that accounting information systems affect the quality of financial information by assisting in providing good accounting information. Wongsim & Jing Gao (2011) agree that AIS affect the quality of information which is then used in making a decision, marked by the dimension of information quality has a positive relationship with the process of adopting AIS (Sri Dewi Anggadini, 2017).

CONCLUSION

User ethics and user competencies applied in State Owner Enterprises have a significant influence on the implementation of IS in partially and simultaneously. Partially, the influence of user ethics variables on the implementation of AIS is more bigger than user competence, this suggests that the implementation of AIS is more influenced by utilitarianism, individual rights and distributive justice of a user in running AIS compared to knowledge and skills owned by users. Furthermore, the implementation of AIS has an impact on the quality of AI, it means that the better the AIS implemented, the higher the quality of AI produced.

The good quality of information produced in an organization is one of the competitive advantages for the organization concerned, the quality of the information provided is important for the success of the system implemented in the organization concerned as a guideline for the implementation of the accounting process (Xu, 2009). AIS produce financial information (Hall, 2007: 21). AIS is very important for the success of an organization, namely by facilitating day-to-day operating processes by providing information that is useful for organizational management (Gelinis et al., 2012: 17). Laudon and Laudon (2014: 14) also mentioned that by implementing a quality AIS can produce quality of financial information, which can be used by users in making decisions.

REFERENCES

- Ahmad, Muhannad, Ayasra, Ahmad & Zawaideh, Farah. 2013. Issues and Problems Related to Data Quality in AIS Implementation. *International Journal of Latest Research in Science and Technology*. Vol. 2. Issue 2. Pp. 17-20.
- Alter, Steven. 2002. *Information Systems Foundation of E-Business*. Fourth Edition. New Jersey : Pearson Education International.
- Alzoubi, Ali. 2011. The Effectiveness of The Accounting information System Under the Enterprise Resources Planning (ERP). *Research Journal of Finance and Accounting*. Vol 2. No. 11. Pp. 10-18.
- Azhar Susanto. 2008. *Sistem Informasi Akuntansi, Struktur-Pengendalian-Resiko-Pengembangan*. Indonesia : Lingga Jaya.
- Bassellier, Genevieve, Reich, Blaize Horner & Benbasat, Izak. 2000. Information Technology Competence of Business Managers : A Definition and Research Model. *Social Sciences and Humanities Research Council of Canada*.
- Bodnar, George H & Hopwood, William S. 2014. *Accounting information System*. New Jersey : Prentice Hall.
- Chen, Charlie C, Liu, Julie Yu Chih, Chen, Houn Gee. 2011. Discriminative Effect of User Influence and User Responsibility on Information System Development Processes and Project Management. *Information and Software Technology*. Pp. 149-158.
- Daoud, Hazar & Triki, Mohamed. 2013. Accounting information Systems in an ERP Environment and Tunisian Firm Performance. *The International Journal of Digital Accounting Research*. 2013. Pp. 1 – 35.
- Dessler, Gary. 2011. *Human Resources Management*. Twelfth Edition. USA : Prentice Hall.
- Gelderman, M. 1998. The Relation Between User Satisfaction, Usage of Information Systems and Performance. *Information and Management*. 34. Pp. 11-18.
- Gelinis, JR, Ulric J, Dull, Richard B & Wheeler, Patrick R. 2012. *Accounting information System*. 9th Edition. USA : South Western Cengage Learning.
- Gorla, Narasimhaiah, Somers, Toni M & Wong, Betty. 2010. Organizational Impact of System Integration, Information Integration, and Service Integration. *Journal of Strategic Information Systems*. 2010. Pp 207-228.
- Guragai, Binod, Hunt Nicholas & Neri, March. 2014. Accounting information Systems and Ethics Research : Review, Synthesis and the Future. *Social Science Research Network*. Pp. 1-40.
- Hall, James A. 2011. *Accounting information System*. 7th Edition. USA : South-Western Publishing Co.

- Hansen, Don R. & Mowen, Maryanne M. 2007. *Managerial Accounting*. 8th Edition. USA: Thomson South Western.
- Hartman, Laura P. & Desjardins, Joe. 2008. *Business Ethics : Decision-Making for Personal Integrity and Social Responsibility*. Singapore : McGraw-Hill Companies.
- Henderson, Richard I. 2006. *Compensation Management in a Knowledge-Based World*. Tenth Edition. USA : Pearson Prentice Hall.
- Hornngren, Charles, Sundem, Gari L, Stratton William L, Burgstahler, David & Schatzberg, Jeff. 2008. *Introduction to Management Accounting*. Fourteenth Edition. USA : Pearson Prentice Hall.
- Kassboll, Jens & Chawani, Marlen Stacey. 2010. Competencies and Learning for Management Information Systems. *Journal of Information, Information Technology, and Organizations*. Vol. 5.Pp. 85-90.
- Kieso, Donald E. Weygandt, Jerry & Warfield, Terry D. 2012. *Intermediate Accounting*. 14th Edition. UK: John Willey and Sons, Inc.
- Kouser, R., Rana, G. and Shahzad, F.A., 2011. Determinants of AIS effectiveness: Assessment thereof in Pakistan. *International Journal of Contemporary Business Studies*, 2(12), pp.6-21.
- Kreitner, Robert & Kinicki, Angelo. 2010. *Organizational Behavior*. Ninth Edition. USA : McGraw-Hill.
- Laudon, Kenneth C & . Laudon, Jane P. 2014. *Management Information Systems Managing The Digital Firm*. Thirteenth Edition. America : Pearson Prentice Hall.
- Mc. Leod, Raymond & Schell, George P. 2007. *Management Information System*. Tenth Edition. Upper Saddle River New Jersey 07458 : Pearson / Prentice Hall.
- McManus, John & Harper, Trevor Wood. 2003. *Information Systems Project Management. Methods, Tools and Techniques*. The United Kingdom : Pearson Education limited.
- Mondy, R. Wayne. 2010. *Human Resources Management*. Eleventh Edition. 2010. USA : Prentice Hall. New Jersey.
- Munirath, Yusuf, Sanni, Isayaka Mohammed & Kazeem, Aina Olalekan 2014. The Impact of Management Information System (MIS) on the Performance of Business Organization in Nigeria. *International Journal of Humanities Social Sciences and Education (IJHSSE)*. Vol 1. Issue 2. Pp 76-86.
- Myers, Michael D & Venable, John R. 2014. A Set of Ethical Principles for Design Science Research in Information Systems. *Information & Management*. 51. Pp. 801-809.
- O'Brien , James A. & Marakas, George M. 2011. *Management Information Systems*. Tenth Edition. New York: McGraw-Hill Irwin.
- Olumoye, Mosud Y. 2013. Ethics and Social Impact of Information Systems in Our Society : Analysis and Recommendation. *International Journal of Science and Research*. Pp. 154-158.
- Ponte, Enrique Bonsón., and Pilar, María. 2000. *The Improvement of Accounting information Systems through the Integration of Emerging Technologies*, Journal [Revista de Contabilidad - Spanish Accounting Review](#)
- Rocheleau, Bruce. 2006. *Public Management Information System*. 2006. All rights Reserved.
- Romney, Marshall B. & Steinbart, Paul J. 2015. *Accounting information Systems*. Global Edition. Thirteenth Edition. USA : Pearson Education Limited.
- Sabherwal, Rajiv, Jeyaraj, Anand & Chowa, Charles. 2006. Information Sistem Success : Individual and Organizational Determinants. *Management Science*. Vol 52. No. 12. Pp. 1849-1846.
- Sajady, Dastgir, Hashem Nejad. 2008. Evaluation of The Efectiveness of Accounting information Systems. *International Journal of Information Science and Technology*. Vol. 6. No. 2. July/December.
- Salehi, Mahdi & Abdipour, Abdoreza. 2011. A Study of the Barriers of Implementation of Accounting information System : Case of Listed Companies in Tehran Stock Exchange. *Journal of Economics and Behavioral Studies*. Vol. 2. No. 2. Pp. 76-85.
- Schermerhorn, John R. 2011. *Introduction to Managemant*. 11th Edition. 2011. Asia : John Wiley & Sons.
- Simkin, Mark G, Rose, Jacob M & Norman, Carolyn Strand. 2013. *Accounting information Systems*. Twelfth Edition. Singapore : John Wiley.
- Sri Dewi Anggadini. 2018. How Can The Information System Be Successful In Its Implementation?. *Archives of Business Research*. Vol.6, No.4, April, 2018. Pp. 237-243.
- Sri Dewi Anggadini. 2017. *Improving The Quality of financial information System Through the Availability of User's Competence*. *Journal of Engineering and Applied Sciences* 12 (Special Issue 11). Pp. 9260-9265.
- Sri Dewi Anggadini. 2017. *Study of Resources Allocation on The Implementation of Accounting information System*. *Journal of Engineering and Applied Sciences* 12 (Special Issue 11). Pp. 9255-9259.
- TaherBelhaj, Faisel Mohamed, Sukoharsono, Eko Ganis & Suyadi, Imam. 2014. The Need for User Competency on the Success of Management Information System Implementation in Oil Companies in Libya. *IOSR Journal of Business and Management*. Vol 16. Issue 7. Pp. 71-78.
- Wongsim, M., & Jing Gao. 2011. *Exploring Information Integration in Accounting information System Adoption*. IBIMA Publishing. Pp. 1-12.

- Wixom, B. H. & Todd, P.A. 2005. A Theoretical Integration of User Satisfaction and Technology Acceptance. *Information Systems Research*. 16.(1). Pp. 85-102.
- Xu, Hongjiang. 2009. Data Quality Issues for Accounting information System' Implementation : Systems, Stakeholders and Organizational Factors. *Journal of Technology Research*.