

B.3.CORRESPONDENCE

TYPE	:	Hasil Penelitian Atau Pemikiran Yang Dipublikasikan Jurnal Ilmiah Internasional.
TITLE	:	Prediction Model Of Internal Control System And Accounting Information Systems And Its Impact To The Quality Of The Local Government Financial Statements
AUTHORS	:	Lilis Puspitawati ^{1*} , Hilmi ² , Nabilah Andri D ³
CORRESPONDENCE	:	Lilis Puspitawati
PUBLISHER	:	IJPUBLICATION
NO/VOL/TAHUN	:	Vol 7, No 2/ 2020

I. CORRESPONDENCE HISTORY

NO	DATE	DESCRIPTION
1	02 February 2020	Submit Full Paper
2	15 February 2020	Need for the Revision Full Paper
3	30 April 2020	Submit revision paper
4	10 May 2020	Article Accepted
5	13 May 2020	Article Payment
6	30 May 2020	Article Published

2. CORRESPONDENCE ACTIVITY

Submit Paper



editor@ijrar.org

Inbox - lilis.puspit...ti@email.unikom.ac.id 1

IJRAR218513 - Acknowledgement from IJRAR regarding research paper submitting

To: lilis.puspitawati@email.unikom.ac.id,

Reply-To: editor@ijrar.org, Editor IJRAR



<p>

Thank you for submitting paper in IJRAR. You will be intimated for final selection & acceptance of your paper very soon.

Your paper will undergo the normal review process of the Journal. The process normally takes 1 to 3 Days to complete depending on the number of rounds the reviews need to take place.</p>

Kindly Note following details for future reference:

Registration ID : IJRAR_218513

Paper Title: PREDICTION MODEL OF INTERNAL CONTROL SYSTEM AND ACCOUNTING INFORMATION SYSTEMS AND ITS IMPACT TO THE QUALITY OF THE LOCAL GOVERNMENT FINANCIAL STATEMENTS

Corresponding Author Name :Lilis Puspitawati

Corresponding Author Email : lilis.puspitawati@email.unikom.ac.id
</p>

IJRAR Journal is UGC and ISSN approved.

2.1. THE 1ST ARTICLE REVISION

TABLE OF CORRECTION

Manuscript Name & Code	:	Prediction Model Of Internal Control System And Accounting Information Systems And Its Impact To The Quality Of The Local Government Financial Statements IJRAR-218513
-----------------------------------	---	---

NO	REVIEWER COMMENTS	AUTHOR'S COMMENTS/RESPONSE
1	Abstract and Title: The aim of the research has not been explained in the abstract	has been corrected according to the reviewer's direction
2	Introduction: 1. There are no references in several sentences 2. An explanation of previous research is needed to describe the novelty of your research	has been corrected according to the reviewer's direction
	Literalure review: 1. Add references 2. Hypothesis Statement	has been corrected according to the reviewer's direction
3	Research Method: collecting data, sample size and basis for sampling are not yet included in the research method	has been corrected according to the reviewer's direction
4	Research Result And Discussion: 1. Complete the research results with data presented in the table 2. Explain whether this research is related to previous research? and whether there is anything new resulting from this research?	has been corrected according to the reviewer's direction
5	Conclusion and Recomendation -none-	has been corrected according to the reviewer's direction
	Reference The reference is not complete, please check again and complete it.	has been corrected according to the reviewer's direction

PAPER WITH REVIEWERS COMMENT

PREDICTION MODEL OF INTERNAL CONTROL SYSTEM AND ACCOUNTING INFORMATION SYSTEMS AND ITS IMPACT TO THE QUALITY OF THE LOCAL GOVERNMENT FINANCIAL STATEMENTS (Survey of the City of Bandung Financial and Asset Management Agency)

Lilis Puspitawati

email: lilis.puspitawati@email.unikom.ac.id¹

Hilmi

email: hilmi@unimal.ac.id²

Nabilah Andri Daneswari

email: nadaneswari@gmail.com³

^{1,3} Program Studi Akuntansi- Universitas Komputer Indonesia (UNIKOM) Bandung

² Program Studi Akuntansi-Universitas Malikussaleh Lhokseumawe

Abstract

The rise of cases of financial statement fraud that occur today shows the low quality of financial reports produced by government agencies in Indonesia. This condition has triggered increasing public mistrust of government financial management both at the center and in the regions. The malfunctioning of the internal control system and the adoption of an Accounting Information System that is not running smoothly triggers the inability of financial reports. Related to these problems,

This research uses descriptive and verification methods using a quantitative approach. The sampling technique uses simple random sampling to obtain a sample size of 52 respondents. The statistical test that will be used to test the conceptual hypothesis is Structural Equation Modeling (SEM) through the Partial Least Square (PLS) approach.

The results of this study indicate that the Internal Control System has a significant effect on the quality of the Regional Government's Financial Statements and the Accounting Information System has a significant effect on the quality of the Regional Government's Financial Statements.

Keywords: Internal Control System, Accounting Information System, Quality of Regional Government Financial Statements.

A. Research Background

Good governance is a manifestation in the framework of local governments that must continue to implement strategies in order to improve regional financial management, because regional management regulates all technical aspects covering the fields of regulations, institutions, regional financial information systems, and improving the quality of human resources. Quality local government financial reports where if the report has the following characteristics the first is reliable, the second is relevant, the third is easy to understand, and finally the fourth can be compared. Quality financial reports indicate that the Regional Head is responsible in accordance with the authority delegated to him in carrying out the responsibility of managing the organization

To be able to produce high-quality local government financial reports an internal control system is needed. The internal control system is a stage process carried out to provide adequate guarantees so that the following control objectives have been achieved. Internal control is also called a stage process because it spreads throughout the company's operating activities and is an integral part of management activities. The problem that occurs in the field is in the control environment where the lack of commitment to the placement of employees in accordance with their competencies. This fact is evidenced by the large number of government finance employees with non-accounting backgrounds, as a result various exercises lack maximum results. This is due to the determined employee selection model that is still general in nature and has not yet explored aspects of the examinees' accounting competence. Poor control environment, will cause the quality of local government reports are not reliable.

In the process of the stages of preparing and presenting the resulting financial statements, the accounting information system has a strong contribution to the quality of the financial statements (Romney and Steinbart, 2009: 10). Accounting information system is a group of structures in an entity that manages physical resources and other resources to convert economic data into accounting information, in order to meet the information needs of various parties (Atvanto Mahatmyo, 2014: 9).

In its implementation, a good accounting information system is expected to be able to provide or produce quality information that is useful for management, especially as well as other users of information in making decisions. There are three main functions of accounting information systems namely to support daily activities, to support the decision making process and to assist in fulfilling financial management responsibilities (Azhar Susanto, 2013: 8). The problems that occur in the field related to accounting information systems on the quality of local government financial reports is the lack of competent human resources in the field of accounting. So that there are still errors or errors in the financial statements that cause financial statements are not reliable.

Author

The aim of the research has not been explained in the abstract

Author

There are no references in several sentences

Based on the background above, the problem of Internal Control Systems, Accounting Information Systems and the Quality of Local Government Financial Reports becomes interesting where it can be researched in order to add information and complete the results of previous studies.

With the aim to be able to find out how much influence the Internal Control System on the Quality of Regional Government Financial Reports and to find out how much influence the Accounting Information System on the Quality of Regional Government Financial Reports. The results of this study are expected to solve the problems that occur in the quality of local government financial reports as well as problems in the internal control system and the accounting information system. Based on the theory built and the resulting empirical evidence, the problems with the quality of local government financial reports can be corrected by improving the internal control system and the accounting information system.

II. LITERATURE REVIEW, CONCEPTUAL FRAMEWORK AND HYPOTHESES

A. Literature Review

1) Internal Control System

The internal control system is an integral process of actions and activities carried out continuously by the leadership and all employees to provide adequate confidence in the achievement of organizational goals through activities that are effective and efficient, the reliability of financial reporting, securing state assets, and compliance with laws. The internal control system is an integral process of actions and activities carried out by management (executive) and its staff to provide adequate assurance or confidence on the achievement of organizational goals through activities that are effective and efficient, reporting reliability finance, securing state assets, and compliance with laws and regulations.

The internal control system is a process that is influenced by management created to provide adequate confidence in achieving effectiveness, efficiency, adherence to applicable laws and regulations, and the reliability of the presentation of financial statements. Based on some of the above understanding, it can be synthesized that the internal control system is an integral process of actions and activities carried out continuously by the leadership and all employees to provide adequate confidence in the observance of laws and regulations. The components of the internal control system (Mahmudi, 2016: 21), are: 1. Control Environment; 2. Risk Assessment; 3. Control Activities; 4. Information and Communication; and 5. Monitoring".

2) Accounting Information Systems

The quality of information systems is the key for an organization to achieve success effectively. System quality is a set of characteristics that can be seen by users after they interact with the system at a certain time (one set of characteristics will be clearly apparent to users after they have interacted with the system for only a short period time). The term success to indicate the quality of information systems, while Stair & Reynolds (2010: 57) shows quality in terms of user satisfaction. Accounting information system is a collection (integration) of sub-systems / components both physical and non-physical which are interrelated and work together in harmony in which the next process can process transaction data related to the problem finance becomes financial information. The accounting information system is a system that will be used as organizing forms, records and reports that are coordinated to be able to produce financial information needed in making management decisions and company leaders and can facilitate in managing a company. The Accounting Information system is a collection of resources such as humans and equipment, which are arranged in such a way as to convert accounting data into accounting information needed by its users. Based on some of the above understanding, it can be synthesized that the accounting information system is a system that collects and processes accounting data into accounting information with the aim of producing accounting information for its users.

The components of accounting information systems according are "1. Hardware (hardware); 2. Software (software); 3. Brainware; 4. Procedure; 5. Database and Database Management Systems; 6. Telecommunications Network Technology".

3) Quality of Regional Government Financial Statements

Information of high quality, that is information products whose characteristics, attributes, or qualities make the information more valuable to them. It is useful to think of information as having the three dimension of time, content and form. The quality of local government financial reports is a combination of financial reports that exist in the local government according to the conceptual framework of PP No. 71 of 2010 Paragraph 24 as a stage to provide relevant information about the financial position and all transactions that will be carried out by a reporting entity during 1 reporting period. The quality of local government financial reports is information that is prepared as helping stakeholders in making social, political and economic decisions so that decisions made to be more quality.

Author

An explanation of previous research is needed to describe the novelty of your research

Author

Add references

Author

Add references

As for some of the definitions above, it can be synthesized that the quality of local government financial reports is information that is presented to help stakeholders provide relevant information about the financial position and all transactions carried out by a reporting entity during one reporting period. characteristics of local government financial statements according are: "1. Relevant; 2. Reliable; 3. Can be compared; 4. Easy to understand".

B. Framework for Thinking

1) Effect of Internal Control Systems on the Quality of Regional Government Financial Statements

Internal control systems can affect the quality of local government financial statements because according to Dadang Suwanda, et al (2017: 65) internal control systems are needed in the process of presenting financial statements. The internal control system is directly related to the presentation of financial statements. Financial reports that are built with an internal control system will produce reliable government financial results.

Several previous studies have shown that internal control systems affect the quality of financial statements. As stated by Teuku Fahrhan Nagor (2015), Ida Ayu Enny Kiranavanti (2016) and Susilawati and Dwi Seftihani (2014) that the internal control system has a significant effect on the quality of local government financial reports.

2) Effect of Accounting Information Systems on the Quality of Regional Government Financial Statements

Accounting information systems affect the quality of regional government financial reports according to Azhar Susanto (2013: 37) The main purpose of accounting information systems is to improve the quality of financial statements, namely information that is effective (reliable), reliable, complete, and reliable (accurate). Several previous studies have proven that accounting information systems affect the quality of government financial reports. As stated by Safrida Yuliani, et al (2010), Rukmi Juwita (2013) and Silviana (2013) that the accounting information system has a positive and significant effect on the quality of financial statements. research conducted by Iilis puspitawati and sri dewi anggadini (2019), proves that accounting information systems affect the quality of accounting information at universities in the city of Bandung. Based on the explanation and frame of mind above, the authors formulated the hypothesis as follows:

III. RESEARCH METHODOLOGY

The research method that will be used in this study, the authors use descriptive research methods and verification methods with a quantitative approach, the results of research which will then be processed and analyzed to draw conclusions. The data source used in this study is primary data, where the authors collect data themselves that will be needed can be sourced directly from the first object to be examined as research by distributing questionnaires to the Financial and Asset Management Agency in Bandung. The primary data contained in this study are the results of the questionnaire answers that have been filled out by respondents.

The definition of population is a generalization area that consists of several objects / subjects that have certain qualities and characteristics determined by researchers to be studied and can then make conclusions (Sugiyono 2017: 80). The population used by researchers is 109 Employees of the City of Bandung Financial and Asset Management. The SEM (Structural Equity Model) - PLS (Partial Least Square) must be determined in advance the minimum sample size (Hair, et al. 2014).

IV. RESEARCH RESULTS AND DISCUSSION

4.1. Descriptive Analysis Results

1) Respondents' Responses regarding Internal Control Systems

The results of calculating the percentage of the total score of the Internal Control System variable are as follows:

Tabel 4.1
total Score of The Internal control System

No	Indicator	Actual Scores	Ideal Scores	% Actual Scores	Criteria
1.	Control Environment	159	260	61,15%	Enough
2.	Risk Assessment	180	260	69,23%	Good
3.	Control Activities	178	260	68,46%	Good
4.	Information and communication	179	260	68,84%	Good
5.	Monitoring	177	260	68,07%	Good
	Total	873	1300	67,15%	Enough

General respondents rated the internal control system variable in good condition, but there is still one indicator with poor results, namely the control environment. this condition illustrates that the organization has not yet

Author

Add references

Author

Hypothesis Statement ?

Author

collecting data, sample size and basis for sampling are not yet included in the research method

applied the norms / rules / guidelines of good internal control within an organization, in the sense that internal control is carried out in the absence of a specific binding policy so that its implementation is voluntary.

2. Respondents' Responses regarding Accounting Information Systems

From the results of the calculation of the percentage of the total score of the Accounting Information System variables as follows:

Tabel 4.2
total Score of The Accounting Information Systems.

No	Indicator	Actual Scores	Ideal Scores	% Actual Scores	Criteria
1.	Hardware	179	260	68,84%	Good
2.	Software	177	260	68,07%	Good
3.	Brainware	133	260	51,15%	enough
4.	Procedure	178	260	68,46%	Good
5.	Database	179	260	68,84%	Good
6.	Communication Network	181	260	69,61%	Good
	Total	873	1300	67,15%	enough

Respondents generally stated that accounting information system variables are in good condition, but for brainware indicators the results are still not good. This condition illustrates that information system users do not yet have sufficient competence because their background knowledge, experience and skills are still lacking or not appropriate to their field of work.

3. Respondents Response Regarding The Quality of Government Financial Statement.

From the results of the calculation of the percentage of the total score of The Quality of Government Financial Statement variables as follows:

Tabel 4.3
total Score of The Quality Of Government Financial Statement .

No	Indicator	Actual Scores	Ideal Scores	% Actual Scores	Criteria
1.	Relevance	179	260	68,84%	Good
2.	Reliability	154	260	59,23%	Enough
3.	Comparability	178	260	68,46%	Good
4.	Understandability	178	260	68,46%	Good
	Total	689	1040	66,25%	enough

Respondents generally stated that The Quality Of Government Financial Statement variables are in good condition, but for reliability indicator the results are still not good. This condition illustrates that Quality of Government financial statement does not yet reflect reliable information for decision making, because the processing of such information is not supported by accurate business transaction data.

4.2. Verificative Analysis Result

Verification analysis using SEM-PLS can be explained as follows:

1. Result of Outer Model test

Outer models are used to see the relationship between variables with indicators, outer models are used to measure whether the indicators used have measured the variable (measurement model) through the Convergent Validity and Discriminant Validity tests. The results of the test are shown below:

a. Convergent Validity

convergent validity is used to assess whether the indicator is right / suitable to be used in measuring the variables studied. Convergent validity can be assessed from the outer loading value which must be more than 0.5. Outer loading values 0.5 to 0.6 are sufficient, whereas if greater than 0.7, it is said to be high.

Discriminant Validity

To assess discriminant validity, Cross loading factor is used, which is a measure that shows the strength of the relationship of indicators with their latent variables. The following results show the cross loading factor for each variable used in the study.

b. Results of Goodness of Fit Test.

Fit test of combination models is a suitability test to validate the overall model, using the Goodness of Fit (GoF) value.

Author

Complete the research results with data presented in the table

The Goodness of Fit (Gof) value of 0.460. Gof value of 0.678 according to Hair, et.al (2014) is classified as strong or high, so it can be concluded that the fitness test results of the goodness of fit model are classified as high.

1. Inner Model (structural model)

After doing the inner model, then the outer model is tested or known as structural model measurement. In testing this structural model will be known to the influence between the variables studied. The structural path coefficient X1 to Y is 0.476 and the structural path coefficient X2 to Y is 0.408. Thus the structural equation model is obtained as follows:

$$Y = 0,476X_1 + 0,408X_2 + \zeta$$

Description

- Y = The Quality Of Government Financial Statement
- X₁ = Internal Control Systems
- X₂ = Accounting Information System
- ζ = Residual atau Error

Furthermore, the hypothesis testing results can be seen as follows:

- a. Based on the table above, the statistical value for the X₁ variable is 6.141. This value is greater than the critical value of 1,677, so it can be concluded that H₀ is rejected and accepts H₁, meaning that the Internal Control System is proven to have a significant effect on the Quality of Regional Government Financial Statements at the Bandung Financial and Asset Management Agency with a contribution of 33.94%.
- b. Based on the table above, the statistical value for the X₂ variable is 4.752. This value is greater than the critical value of 1,677, so it can be concluded that H₀ is rejected and accepts H₁, meaning that the Accounting Information System is proven to affect the Quality of Regional Government Financial Statements in the Financial and Asset Management Agency in Bandung with a contribution of 27.95%.

Furthermore, we can be presented Full Model as follows:

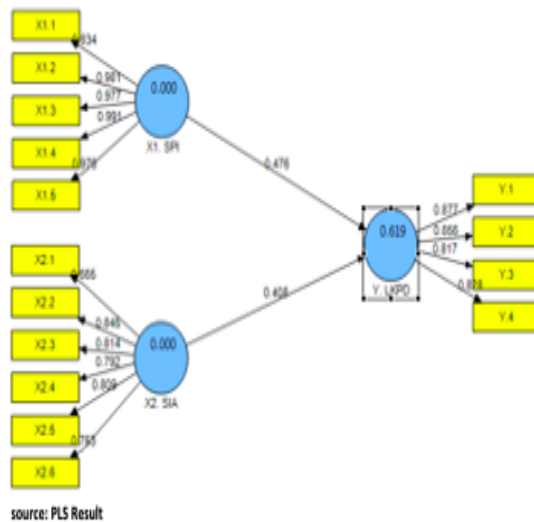

4.3. Discussion

4.3.1. The Effect of Internal Control Systems on the Quality of Regional Government Financial Statements

The internal control system has an effect on the quality of local government financial reports reaching 33.94%. The relationship of internal control systems to the quality of local government financial reports is positive, which means the better the internal control system that will make the quality of local government financial reports better. The results of this study are supported by the theory in the previous discussion, according to Nuramalia Hasanah and Achmad Fauzi (2016: 181) that the internal control system is an action and activity carried out by management (executive) and its staff, one of which is to provide adequate assurance or confidence in the quality of the report. local government finance.

Author

Explain whether this research is related to previous research? and whether there is anything new resulting from this research?

This answers the phenomenon of the Internal Control System on the Quality of Regional Government Financial Statements that in a control environment where there is a lack of commitment to the placement of employees according to their competence. This fact is evidenced by the large number of government finance employees with non-accounting backgrounds, as a result various exercises lack maximum results. This is due to the determined employee selection model that is still general in nature and has not yet explored aspects of the examinees' accounting competencies so that the control environment is not good, causing the quality of local government reports to decline. This is in line with the results of research showing a positive relationship between the Internal Control System and the Quality of Local Government Financial Statements. this is evidenced by the indicator with the lowest score of the respondent's response is the environmental control indicator of 61.15% is categorized quite well, but there is still a gap of 38.85%. Where in the control environment there is still a lack of commitment to assigning employees according to their competencies.

4.3.2. The Effect of Accounting Information Systems on the Quality of Regional Government Financial Statements

Accounting information systems have an effect on the quality of local government financial statements of 27.95%. The relationship of accounting information systems to the quality of local government financial reports is positive, which means the better the accounting information system will make the quality of financial statements of local governments better. The results of this study are supported by the theory in the previous discussion, according to (Azhar Susanto, 2013: 37) that the main purpose of an accounting information system is to improve the quality of financial statements, namely information that is effective (complete), complete, reliable, and trusted (accurate).

This answers the phenomenon of Accounting Information Systems on the Quality of Regional Government Financial Statements that in Brainware (Humans) where there is still a lack of competent human resources in the field of accounting. So that mistakes or errors are still found on the financial statements. This can be proven by the indicator that the lowest score of the respondent's response is an indicator of Brainware (Human) of 51.15% which is quite good, but there is still a gap of 48.84%.

V. CONCLUSIONS AND SUGGESTIONS

A. Conclusion

Based on the results of research and discussion that has been done about the influence of Internal Control Systems and Accounting Information Systems on the Quality of Local Government Financial Statements in the City of Bandung Financial and Asset Management Agency, at the end of this study, from this study where the authors can draw conclusions as following:

1. Internal Control System influences the Quality of Regional Government Financial Statements, where the better the Internal Control System will improve the Quality of Regional Government Financial Statements and vice versa.
2. Accounting Information Systems affect the Quality of Regional Government Financial Statements, where if the Accounting Information System is better, it will improve the Quality of Regional Government Financial Statements and vice versa.

B. Suggestions

Based on the conclusions above where the author can give the following advice:

1. The Internal Control System is proven to have an effect on the Quality of Regional Government Financial Statements, therefore to improve the Quality of Regional Government Financial Statements, the Internal Control System that needs to be given attention is on the environmental control indicators where the Regional Government must more often provide training and seminars to each of its employees, especially regarding the preparation of regional financial reports, besides that the Regional Government must be more selective in selecting its employees, the Regional Government must be able to ensure that employees who pass the recruitment selection have sufficient competence, so that the Regional Government can maintain the Quality of the Regional Government's Financial Statements.
2. Accounting Information Systems have proven to have an effect on the Quality of Regional Government Financial Statements, therefore to improve the Quality of Regional Government Financial Statements, the Accounting Information System that needs to be given focus is on Brainware (Human) indicators, where the Regional Government needs to evaluate whether its accounting staff are correct really understand accounting standards that are in line with local government or not, local governments must ensure that accounting staff are able to make reports in accordance with SAP in force to minimize errors

in the preparation of financial reports and the quality of Regional Government Financial Reports can increase.

3. For the Development of Accounting, it is expected to be able to provide additional knowledge, as a source of information and as a contribution of thought in developing the public sector accounting discipline, as well as contributing to the development of research in particular regarding Internal Control Systems and Accounting Information Systems on the Quality of Regional Government Financial Statements.
4. For Researchers Furthermore, it is expected to be used as a reference so that in the future other researchers can use the same method with a record of variables, units of analysis, populations and different samples in order to obtain conclusions that support the theory and concept generally accepted

DAFTAR PUSTAKA

- Atvanto Mahatmvo. 2014. *Sistem Informasi Akuntansi Suatu Pengantar*. Yogyakarta: Deepublish.
- Azhar Susanto. 2013. *Sistem Informasi Akuntansi*. Bandung: Lingga Jaya.
- Baldric Siregar. 2017. *Akuntansi Sektor Publik*. Yogyakarta: Unit Penerbit dan Percetakan Sekolah Tinggi Ilmu Manajemen YKPN.
- Dadang Suwanda. 2017. *Panduan Penerapan Reviu Laporan Keuangan Pemerintah Daerah*. Bandung: PT Remaja Rosdakarya.
- Dwi Ratmono dan Mahfud Sholihin. 2015. *Akuntansi Keuangan Daerah Berbasis Akrual*. Yogyakarta: Unit Penerbit dan Percetakan Sekolah Tinggi Ilmu Manajemen YKPN.
- Ida Ayu Enny Kiranavanti. 2016. *Pengaruh Sumber Daya Manusia, Sistem Pengendalian Intern, Pemahaman Basis Akrual terhadap Kualitas Laporan Keuangan Daerah*. E-Jurnal Akuntansi Universitas Udayana. (Volume 16. 2 Agustus 2016; Hal. 1290-1318).
- Lilis Puspitawati & Sri Dewi Anggadini. 2011. *Sistem Informasi Akuntansi*. Yogyakarta: Graha Ilmu.
- Lilis Puspitawati & Sri Dewi Anggadini. 2019. The Influence of the Quality Accounting Information system to Quality of Accounting Information-Evidence in Indonesia. *Majalah Ilmiah Unikom*, Vol.17, No.1.
- Mahmudi. 2010. *Manajemen Kinerja Sektor Publik*. Yogyakarta: Unit Penerbit dan Percetakan Sekolah Tinggi Ilmu Manajemen YKPN.
- Mahmudi. 2016. *Analisis Laporan Keuangan Pemerintah Daerah*. Yogyakarta: Unit Penerbit dan Percetakan Sekolah Tinggi Ilmu Manajemen YKPN.
- Marakas, George M & James A. O'Brien. 2014. *Introduction to information System*. Sixteenth Edition. Boston: McGraw-Hill, Inc.
- Moh Mahsun. 2016. *Akuntansi Sektor Publik*. Yogyakarta: BPFE.
- Nuramalia Hasanah dan Achmad Fauzi. 2016. *Akuntansi Pemerintahan*. Jakarta: In Media.
- Puspitawati, L., Susanto, A., Poulus, S., Supriadi, J. (2018). The critical success factors of the business strategy in the effectiveness of Management Accounting Information System evidence in Indonesia. *Journal of Engineering and Applied Sciences*. Vol.13.No.15. 2018
- Rizki Ahmad Fauzi. 2017. *Sistem Informasi Akuntansi (Berbasis Akuntansi)*. Yogyakarta: Deepublish.
- Rukmi Juwita. 2013. *Pengaruh Implementasi Standar Akuntansi Pemerintahan dan Sistem Informasi Akuntansi terhadap Kualitas Laporan Keuangan*. *Jurnal Trikomonika*, (Volume 12, No. 2, Desember 2013; Hal. 201-214).
- Safriada Yuliani, Nadriyah dan Bakar, Usman. 2010. *Pengaruh Pemahaman Akuntansi, Pemanfaatan Sistem Informasi Akuntansi Keuangan Daerah dan Peran Internal Audit terhadap Kualitas Laporan Keuangan Pemerintah Daerah*. *JURNAL TELAHAH & RISET AKUNTANSI*. (Vol. 3. No. 2. Juli 2010; Hal. 206-220).
- Silviana. 2013. *Hubungan Penerapan Sistem Informasi Akuntansi terhadap Kualitas Laporan Keuangan Pemerintah Daerah*. *Proceeding Call for Papers dan Seminar Nasional Fakultas Ekonomi UNS*. (30-31 Mei 2013).
- Susilawati dan Dwi Seftihani Riana. 2014. *Standar Akuntansi Pemerintahan dan Sistem pengendalian Intern sebagai Antecedent Kualitas Laporan Keuangan Pemerintah Daerah*. *Star-Study & Accounting Research*. (Volume XI, No. 1, 2014; Hal. 15-32).
- Teuku Fabrian Nangor, Darwanis, dan Abdullah, Syukriy. 2015. *Pengaruh Penerapan Sistem Pengendalian Intern dan Penerapan Prinsip Pengelolaan Keuangan Daerah terhadap Kualitas Laporan Keuangan Pemerintah Daerah Kabupaten Aceh Barat: Studi pada SKPD Pemerintah Daerah Kabupaten Aceh Barat*. *Jurnal Magister Akuntansi Pascasarjana Universitas Syiah Kuala*. (Volume 4, No. 1, Februari 2015; Hal. 72- 79).

Author

The reference is not complete, please check again and complete it

★ LP Lilis Puspitawati

12 May 2020 13:12

Request revision of email address in the article before it is published

To: IJRAR Journal

Dear editorial

I have paid my article IJRAR-218513 with the title prediction model of internal control system and accounting information system and its impact to the Quality of the local government financial statement

in the article there was an error writing the email address for the second author. The email address that should be hilmi@unimal.ac.id, please fix it before publishing, I send the revised article for the second author's email address.

For your attention and cooperation I thank you

Best Regards
Lilis puspitawati



PREDICTION
MODE...docx

IJ IJRAR Journal

13 May 2020 13:24

Re: Request revision of email address in the article before it is published

To: Lilis Puspitawati

Mail id updated

hilmi@unimal.ac.id

send final paper with payment receipt

[See More](#) from Lilis Puspitawati

2.2. ACCEPTED FOR PUBLICATION

Dear Author
 Congratulation!! Your manuscript with Registration ID: **IJRAR_ 218513** has been **accepted** for publication in the INTERNATIONAL JOURNAL OF RESEARCH AND ANALYTICAL REVIEWS (IJRAR)
 E-ISSN 2348-1269, P- ISSN 2349-5138 | Impact factor: 5.75 (IJRAR) | www.ijrar.org.
 Your Review Report is as follows: (IJRAR Impact Factor: 5.75)
 Check your paper status: <http://ijrar.org/Authorhome/login.php>

Review Report	
Registration ID:	IJRAR_ 218513
Title of the Paper:	PREDICTION MODEL OF INTERNAL CONTROL SYSTEM AND ACCOUNTING INFORMATION SYSTEMS AND ITS IMPACT TO THE QUALITY OF THE LOCAL GOVERNMENT FINANCIAL STATEMENTS
Accepted or Not:	Accepted
Criteria	Points out of 10
Continuity	7
Text structure	8
References	8
Understanding and Illustrations	7
Explanatory power	7
Detailing	8
Relevance and practical advice	7
Overall Assessment (Comments.)	
Unique Contents: 78%	

Publication of Paper	Within 02-05 Days after Submitting documents.
REQUEST FORM FOR HARD COPY OF CERTIFICATE	http://ijrar.org/paymentInfo.php

For the pre-publication preparation, please complete the registration process as follow:

STEP 1: Pay Publication fees
 (See following fees structure) *

Author Category	Indian Author*	International Author*
Author	2100 Rs.	55 \$

*Charges include publication of one entire Research Paper Online, Individual Certificate for all authors (Softcopy), Confirmation Letter (Softcopy), Charges, Indexing, and Soft copy of Journal, typesetting, Paper formatting, maintenance of Website and journal infrastructures.

[How to Pay Publication Fees?](#)

IJRAR.ORG **E-ISSN: 2348-1269, P-ISSN: 2349-5138**



INTERNATIONAL JOURNAL OF RESEARCH AND ANALYTICAL REVIEWS (IJRAR) | IJRAR.ORG
 An International Open Access, Peer-reviewed, Refereed Journal

Ref No : IJRAR/Vol 7 / Issue 2/ 457

To,
Lilis Puspitawati
Publication Date 2020-05-10 08:54:33

Subject: Publication of paper at International Journal of Research and Analytical Reviews (IJRAR).

Dear Author,

With Greetings we are informing you that your paper has been successfully published in the International Journal of Research and Analytical Reviews (IJRAR) - IJRAR (E-ISSN 2348-1269, P- ISSN 2349-5138). Thank you very much for your patience and cooperation during the submission of paper to final publication Process. It gives me immense pleasure to send the certificate of publication in our Journal. Following are the details regarding the published paper.

About IJRAR : UGC and ISSN Approved - International Peer Reviewed Journal, Refereed Journal, Indexed Journal, Impact Factor: 7.17, E-ISSN 2348-1269, P- ISSN 2349-5138

UGC Approval : UGC Approved Journal No: 43602
 Registration ID : IJRAR_218513
 Paper ID : IJRAR19L1457
 Title of Paper : PREDICTION MODEL OF INTERNAL CONTROL SYSTEM AND ACCOUNTING INFORMATION SYSTEMS AND ITS IMPACT TO THE QUALITY OF THE LOCAL GOVERNMENT FINANCIAL STATEMENTS

Impact Factor : 7.17 (Calculate by Google Scholar) | License by Creative Common 3.0
 DOI :
 Published in : Volume 7 | Issue 2 | May 2020
 Publication Date: 2020-05-10 08:54:33
 Page No : 533-540
 Published URL : http://www.ijrar.org/viewfull.php?&p_id=IJRAR19L1457
 Authors : Lilis Puspitawati, Hilmi, Nabilah Andri. D

Thank you very much for publishing your article in IJRAR. We would appreciate if you continue your support and keep sharing your knowledge by writing for our journal IJRAR.

R. B. Joshi
 Editor In Chief
 International Journal of Research and Analytical Reviews - IJRAR
 (E-ISSN 2348-1269, P- ISSN 2349-5138)





An International Scholarly, Open Access, Multi-disciplinary, Monthly, indexing in all Major Database & Metadata, Citation Generator

Manage By: IJPUBLICATION Website: www.ijrar.org | Email ID: editor@ijrar.org

2.3. ARTICLE PAYMENT

Paid with

PayPal balance

Ship to

Wahyu Cahyadi
Jl. Teratai Putih I / GG. 16 No.31 RT/RW: 006/004
Jakarta 13460
DKI Jakarta
Indonesia

Transaction ID

1KE134980P796394Y

Sent to

Research Journal Publication
+91 9898157864
editor@ijedr.org

Note

payment IJRAR_ 218513 -PREDICTION MODEL OF INTERNAL CONTROL SYSTEM AND ACCOUNTING INFORMATION SYSTEMS AND ITS IMPACT TO THE QUALITY OF THE LOCAL GOVERNMENT FINANCIAL STATEMENTS

Details

Sent to Research Journal Publication

55,00 \$

2.4. ARTICLE PUBLISHED

[IJRAR](#) [Contact Us](#) editor@ijrar.org [Peer Review , Refereed , Indexed , Multidisciplinary, Multilanguage, Open access Online, Print Journal](#)

[WhatsApp Only +91 635477117](#) [All Policy](#) [Call For Paper](#) [Submit Paper Online](#) [Current Issue](#) [Archive](#) [Paper Status/ Login](#)



INTERNATIONAL JOURNAL OF RESEARCH AND ANALYTICAL REVIEWS (IJRAR.ORG)

[International Peer Reviewed & Refereed Journal, Open Access Journal](#)

[ISSN Approved Journal No: E-ISSN 2348-1269, P- ISSN 2349-5138](#)
[Journal ESTD Year: 2014](#)

[Call For Paper - Volume 10 | Issue 4 | Month- October 2023](#)

[Read all new guidelines related publication before submission or publication. Scholarly open access , Peer-reviewed, and Refereed, Impact Factor: 7.17, AI-Powered Research Tool , Multidisciplinary, Monthly, Indexing in all major database & Metadata, Citation Generator, Digital Object Identifier\(DOI\), UGC Approved Journal No: 43602\(19\)](#)

[Submit Paper](#)
[Login to Author Home](#)
[IJRAR.COM Repository](#)
[Communication Guidelines](#)

[HOME](#) [IJRAR](#) [EDITORIAL](#) [FOR AUTHOR](#) [CURRENT ISSUE](#) [ARCHIVE](#) [CONFERENCE PROPOSAL](#) [SUBMIT PAPER ONLINE](#) [More..](#)

Published Paper Details:

Paper Title
PREDICTION MODEL OF INTERNAL CONTROL SYSTEM AND ACCOUNTING INFORMATION SYSTEMS AND ITS IMPACT TO THE QUALITY OF THE LOCAL GOVERNMENT FINANCIAL STATEMENTS

[Click Here to Download Article](#)

[Published Paper PDF : - http://www.ijrar.org/papers/IJAR19L1457](http://www.ijrar.org/papers/IJAR19L1457)
[Published Paper URL : - http://ijrar/viewfull.php?id=IJRAR19L1457](http://ijrar/viewfull.php?id=IJRAR19L1457)
[Published Paper PDF Download: - download.php?title=IJRAR19L1457](download.php?title=IJRAR19L1457)

Authors
Lilis Puspitawati, Himi, Nabliah Andri. D

IJRAR.ORG

IJRAR is Peer Review
Refereed
Open access
Monthly, Multidisciplinary, Multilanguage
Online, Print Journal
ISSN Approved

[Contact Us](#)
[WhatsApp](#)
[Contact](#)
[Click Here](#)

ISSN
INTERNATIONAL JOURNAL OF RESEARCH AND ANALYTICAL REVIEWS

E-ISSN
2348-1269,
P- ISSN 2349-5138

[Send message](#)

2.5. CERTIFICATED

Certificate of Publication



INTERNATIONAL JOURNAL OF RESEARCH AND ANALYTICAL REVIEWS (IJRAR) | IJRAR.ORG
An International Open Access, Peer-reviewed, Refereed Journal
E-ISSN: 2348-1269, P-ISSN: 2349-5138

IJRAR | E-ISSN: 2348-1269, P-ISSN: 2349-5138

The Board of
International Journal of Research and Analytical Reviews (IJRAR)
Is hereby awarding this certificate to
Lilis Puspitawati
In recognition of the publication of the paper entitled
PREDICTION MODEL OF INTERNAL CONTROL SYSTEM AND ACCOUNTING INFORMATION SYSTEMS AND ITS IMPACT TO THE QUALITY OF THE LOCAL GOVERNMENT FINANCIAL STATEMENTS

Published in IJRARR (www.ijrar.org) UGC Approved - Journal No : 43602 & 7.17 Impact Factor
Volume 7 Issue 2 May 2020, Date of Publication: 10-May-2020

PAPER ID : IJRAR19L1457
Registration ID : 218513



R.B. Joshi
EDITOR IN CHIEF

UGC and ISSN Approved - Scholarly open access Journals, Peer-reviewed, and Refereed Journals, Impact factor 7.17 (Calculate by google scholar and Semantic Scholar | AI-Powered Research Tool) . Multidisciplinary, Monthly Journal
INTERNATIONAL JOURNAL OF RESEARCH AND ANALYTICAL REVIEWS | IJRAR
An International Scholarly, Open Access, Multi-disciplinary, Indexed Journal
Website: www.ijrar.org | Email: editor@ijrar.org | ESTD: 2014
Managed By: IJPUBLICATION Website: www.ijrar.org | Email ID: editor@ijrar.org

PREDICTION MODEL OF INTERNAL CONTROL SYSTEM AND ACCOUNTING INFORMATION SYSTEMS AND ITS IMPACT TO THE QUALITY OF THE LOCAL GOVERNMENT FINANCIAL STATEMENTS

(Survey of the City of Bandung Financial and Asset Management Agency)

Lilis Puspitawati
Hilmi
Nabilah Andri Daneswari

^{1,3} Program Studi Akuntansi- Universitas Komputer Indonesia (UNIKOM) Bandung

² Program Studi Akuntansi-Universitas Malikussaleh Lhokseumawe

Abstract

The rise of cases of financial statement fraud that occur today shows the low quality of financial reports produced by government agencies in Indonesia. This condition has triggered increasing public mistrust of government financial management both at the center and in the regions. The malfunctioning of the internal control system and the adoption of an Accounting Information System that is not running smoothly triggers the inability of financial reports. Related to these problems, the purpose of this study is to determine the effect of the Internal Control System and Accounting Information System on the Quality of Regional Government Financial Statements in the Financial and Asset Management Agency in Bandung.

This research uses descriptive and verification methods using a quantitative approach. The sampling technique uses simple random sampling to obtain a sample size of 52 respondents. The statistical test that will be used to test the conceptual hypothesis is Structural Equation Modeling (SEM) through the Partial Least Square (PLS) approach.

The results of this study indicate that the Internal Control System has a significant effect on the quality of the Regional Government's Financial Statements and the Accounting Information System has a significant effect on the quality of the Regional Government's Financial Statements.

Keywords: Internal Control System, Accounting Information System, Quality of Regional Government Financial Statements.

A. Research Background

Good governance is a manifestation in the framework of local governments that must continue to implement strategies in order to improve regional financial management, because regional management regulates all technical aspects covering the fields of regulations, institutions, regional financial information systems, and improving the quality of human resources (Dadang Suwanda, et al, 2017: 1).

Quality local government financial reports where if the report has the following characteristics the first is reliable, the second is relevant, the third is easy to understand, and finally the fourth can be compared. Quality financial reports indicate that the Regional Head is responsible in accordance with the authority delegated to him in carrying out the responsibility of managing the organization (Moh. Mahsun, 2016: 35).

To be able to produce high-quality local government financial reports an internal control system is needed (Mahmudi 2010: 27). The internal control system is a stage process carried out to provide adequate guarantees so that the following control objectives have been achieved. Internal control is also called a stage process because it spreads throughout the company's operating activities and is an integral part of management activities (Marshall B. Romney and Paul John Steinbart, 2015: 226). The problem that occurs in the field is in the control environment where the lack of commitment to the placement of employees in accordance with their competencies. This fact is evidenced by the large number of government finance employees with non-accounting backgrounds, as a result various exercises lack maximum results. This is due to the determined employee selection model that is still general in nature and has not yet explored aspects of the examinees' accounting competence. Poor control environment, will cause the quality of local government reports are not reliable.

In the process of the stages of preparing and presenting the resulting financial statements, the accounting information system has a strong contribution to the quality of the financial statements (Romney and Steinbart 2009: 10). Accounting information system is a group of structures in an entity that manages physical resources and other resources to convert economic data into accounting information, in order to meet the information needs of various parties (Atyanto Mahatmyo, 2014: 9).

In its implementation, a good accounting information system is expected to be able to provide or produce quality information that is useful for management, especially as well as other users of information in making decisions. There are three main functions of accounting information systems namely to support daily activities, to support the decision making process and to assist in fulfilling financial management responsibilities (Azhar Susanto, 2013: 8). The problems that occur in the field related to accounting information systems on the quality of local government financial reports is the lack of competent human resources in the field of accounting. So that there are still errors or errors in the financial statements that cause financial statements are not reliable.

Based on the background above, the problem of Internal Control Systems, Accounting Information Systems and the Quality of Local Government Financial Reports becomes interesting where it can be researched in order to add information and complete the results of previous studies.

With the aim to be able to find out how much influence the Internal Control System on the Quality of Regional Government Financial Reports and to find out how much influence the Accounting Information System on the Quality of Regional Government Financial Reports. The results of this study are expected to solve the problems that occur in the quality of local government financial reports as well as problems in the internal control system and the accounting information system. Based on the theory built and the resulting empirical evidence, the problems with the quality of local government financial reports can be corrected by improving the internal control system and the accounting information system.

II. LITERATURE REVIEW, CONCEPTUAL FRAMEWORK AND HYPOTHESES

A. Literature Review

1) Internal Control System

According to Nurmalia Hasanah and Achmad Fauzi (2016: 180) the internal control system is an integral process of actions and activities carried out continuously by the leadership and all employees to provide adequate confidence in the achievement of organizational goals through activities that are effective and efficient, the reliability of financial reporting, securing state assets, and compliance with laws.

As according to Mahmudi (2016: 20) states that the internal control system is an integral process of actions and activities carried out by management (executive) and its staff to provide adequate assurance or confidence on the achievement of organizational goals through activities that are effective and efficient, reporting reliability finance, securing state assets, and compliance with laws and regulations.

Furthermore Dadang Suwanda (2017: 67) states that the internal control system is a process that is influenced by management created to provide adequate confidence in achieving effectiveness, efficiency, adherence to applicable laws and regulations, and the reliability of the presentation of financial statements.

Based on some of the above understanding, it can be synthesized that the internal control system is an integral process of actions and activities carried out continuously by the leadership and all employees to provide adequate confidence in the observance of laws and regulations. The components of the internal control system (Mahmudi, 2016: 21), are: 1. Control Environment; 2. Risk Assessment; 3. Control Activities; 4. Information and Communication; and 5. Monitoring.

2) Accounting Information Systems

The quality of information systems is the key for an organization to achieve success effectively (Rocheleau, 2006: 33). According to Weber (1999: 895), system quality is a set of characteristics that can be seen by users after they interact with the system at a certain time (one set of characteristics will be clearly apparent to users after they have interacted with the system for only a short period time). DeLone & McLean (1992 & 2003) use the term success to indicate the quality of information systems, while Stair & Reynolds (2010: 57) shows quality in terms of user satisfaction.

Azhar Susanto (2013: 72) accounting information system is a collection (integration) of sub-systems / components both physical and non-physical which are interrelated and work together in harmony in which the next process can process transaction data related to the problem finance becomes financial information. Furthermore according to Lilis Puspitawati and Sri Dewi Anggadini (2014:57) states that the accounting information system is a system that will be used as organizing forms, records and reports that are coordinated to be able to produce financial information needed in making management decisions and company leaders and can facilitate in managing a company.

Then according to Rizki Ahmad Fauzi (2017:25) states that the Accounting Information system is a collection of resources such as humans and equipment, which are arranged in such a way as to convert accounting data into accounting information needed by its users. Based on some of the above understanding, it can be synthesized that the accounting information system is a system that collects and processes accounting data into accounting information with the aim of producing accounting information for its users.

The components of accounting information systems according to Azhar Susanto (2013: 207): "1. Hardware (hardware); 2. Software (software); 3. Brainware; 4. Procedure; 5. Database and Database Management Systems; 6. Telecommunications Network Technology".

3) Quality of Regional Government Financial Statements

O'Brien & Marakas (2014) argues that Information of high quality, that is information products whose characteristics, attributes, or qualities make the information more valuable to them. It is useful to think of information as having the three dimension of time, content and form. Furthermore Dwi Ratmono and Mahfud Sholihin (2015: 19) the quality of local government financial reports is a combination of financial reports that exist in the local government according to the conceptual framework of PP No. 71 of 2010 Paragraph 24 as a stage to provide relevant information about the financial position and all transactions that will be carried out by a reporting entity during 1 reporting period. Then Mahmudi (2016: 13) the quality of local government financial reports is information that is prepared as helping stakeholders in making social, political and economic decisions so that decisions made to be more quality.

As for some of the definitions above, it can be synthesized that the quality of local government financial reports is information that is presented to help stakeholders provide relevant information about the financial position and all transactions carried out by a reporting entity during one reporting period. characteristics of local government financial statements according to Baldrick Siregar (2017: 112): "1. Relevant; 2. Reliable; 3. Can be compared; 4. Easy to understand".

B. Framework for Thinking

1) Effect of Internal Control Systems on the Quality of Regional Government Financial Statements

Internal control systems can affect the quality of local government financial statements because according to Dadang Suwanda, et al (2017: 65) internal control systems are needed in the process of presenting financial statements. The internal control system is directly related to the presentation of financial statements. Financial reports that are built with an internal control system will produce reliable government financial results.

Several previous studies have shown that internal control systems affect the quality of financial statements. As stated by Teuku Fahrian Nagor (2015), Ida Ayu Enny Kiranayanti (2016) and Susilawati and Dwi Seftihani (2014) that the internal control system has a significant effect on the quality of local government financial reports.

2) Effect of Accounting Information Systems on the Quality of Regional Government Financial Statements

Accounting information systems affect the quality of regional government financial reports according to Azhar Susanto (2013: 37) The main purpose of accounting information systems is to improve the quality of financial statements, namely information that is effective (reliable), reliable, complete, and reliable (accurate). Several previous studies have proven that accounting information systems affect the quality of government financial reports. As stated by Safrida Yuliani, et al (2010), Rukmi Juwita (2013) and Silviana (2013) that the accounting information system has a positive and significant effect on the quality of financial statements. research conducted by lilis puspitawati and sri dewi anggadini (2019), proves that accounting information systems affect the quality of accounting information at universities in the city of Bandung. Based on the explanation and frame of mind above, the authors formulated the hypothesis as follows:

H1: Internal Control System influences the Quality of Regional Government Financial Statements.

H2: Accounting Information Systems affect the Quality of Regional Government Financial Statements.

III. RESEARCH METHODOLOGY

The research method that will be used in this study, the authors use descriptive research methods and verification methods with a quantitative approach, the results of research which will then be processed and analyzed to draw conclusions. The data source used in this study is primary data, where the authors collect data themselves that will be needed can be sourced directly from the first object to be examined as research by distributing questionnaires to the Financial and Asset Management Agency in Bandung. The primary data contained in this study are the results of the questionnaire answers that have been filled out by respondents.

Data collection techniques that will be used in this study by field research, namely through interviews and distributing questionnaires conducted at the City of Bandung Financial and Asset Management Agency regarding internal control systems, accounting information systems and quality of government financial statements area.

The definition of population is a generalization area that consists of several objects / subjects that have certain qualities and characteristics determined by researchers to be studied and can then make conclusions (Sugiyono 2017: 80). The population used by researchers is 109 Employees of the City of Bandung Financial and Asset Management. The SEM (Structural Equity Model) - PLS (Partial Least Square) must be determined in advance the minimum sample size (Hair, et al. 2014). In this study Minimum sample criteria are determined based on Power analysis so that the sample size to be examined is the 52 respondent. then 52 respondents were selected using a simple random sampling technique.

IV. RESEARCH RESULTS AND DISCUSSION

4.1. Descriptive Analysis Results

1) Respondents' Responses regarding Internal Control Systems

The results of calculating the percentage of the total score of the Internal Control System variable are as follows:

Tabel 4.1
total Score of The Internal control System

No	Indicator	Actual Scores	Ideal Scores	% Actual Scores	Criteria
1.	Control Environment	159	260	61,15%	Enough
2.	Risk Assessment	180	260	69,23%	Good
3.	Control Activities	178	260	68,46%	Good
4.	Information and communication	179	260	68,84%	Good
5.	Monitoring	177	260	68.07%	Baik
	Total	873	1300	67,15%	Enough

General respondents rated the internal control system variable in good condition, but there is still one indicator with poor results, namely the control environment. this condition illustrates that the organization has not yet applied the norms / rules / guidelines of good internal control within an organization, in the sense that internal control is carried out in the absence of a specific binding policy so that its implementation is voluntary.

2. Respondents' Responses regarding Accounting Information Systems

From the results of the calculation of the percentage of the total score of the Accounting Information System variables as follows:

Tabel 4.2
total Score of The Accounting Information Systems.

No	Indicator	Actual Scores	Ideal Scores	% Actual Scores	Criteria
1.	Hardware	179	260	68,84%	Good
2.	Software	177	260	68,07%	Good
3.	Brainware	133	260	51,15%	enough
4.	Procedure	178	260	68,46%	Good
5.	Database	179	260	68,84%	Good
6.	Communication Network	181	260	69,61%	Good
	Total	873	1300	67,15%	enough

Respondents generally stated that accounting information system variables are in good condition, but for brainware indicators the results are still not good. This condition illustrates that information system users do not yet have sufficient competence because their background knowledge, experience and skills are still lacking or not appropriate to their field of work.

3. Respondents Response Regarding The Quality of Government Financial Statement.

From the results of the calculation of the percentage of the total score of The Quality of Government Financial Statement variables as follows:

Tabel 4.3
total Score of The Quality Of Government Financial Statement .

No	Indicator	Actual Scores	Ideal Scores	% Actual Scores	Criteria
1.	Relevance	179	260	68,84%	Good
2.	Reliability	154	260	59,23%	Enough
3.	Comparability	178	260	68,46%	Good
4.	Understandability	178	260	68,46%	Good
	Total	689	1040	66,25%	enough

Respondents generally stated that The Quality Of Government Financial Statement variables are in good condition, but for reliability indicator the results are still not good. This condition illustrates that Quality of Government financial statement does not yet reflect reliable information for decision making, because the processing of such information is not supported by accurate business transaction data.

4.2. Verificative Analisis Result

Verification analysis using SEM-PLS can be explained as follows:

1. Result of Outer Model test

Outer models are used to see the relationship between variables with indicators, outer models are used to measure whether the indicators used have measured the variable (measurement model) through the Convergent Validity and Discriminant Validity tests. The results of the test are shown below:

a. Convergent Validity

convergent validity is used to assess whether the indicator is right / suitable to be used in measuring the variables studied. Convergent validity can be assessed from the outer loading value which must be more than 0.5. Outer loading values 0.5 to 0.6 are sufficient, whereas if greater than 0.7, it is said to be high. The following is the loading factor value for each indicator in table 4.4 below:

Tabel 4.4.
Loading factor result

Internal Control Systems		Loading Factor	tcount	Description
X _{1.1}	Control Environment	0.834	37.208	Valid
X _{1.2}	Risk Assessment	0.981	131.720	Valid
X _{1.3}	Control Activities	0.977	86.189	Valid
X _{1.4}	Information and communication	0.990	520.105	Valid
X _{1.5}	Control Environment	0.976	116.786	Valid
Accounting Information System		Loading Factor	t _{hitung}	Keterangan
X _{2.1}	Hardware	0.765	10.518	Valid
X _{2.2}	Software	0.845	24.657	Valid
X _{2.3}	Brainware	0.813	18.253	Valid
X _{2.4}	Procedure	0.792	15.240	Valid
X _{2.5}	Database	0.809	18.763	Valid
X _{2.6}	Communication Network	0.753	11.717	Valid
The Quality Of Government Financial Statement		Loading Factor	tcount	Description
Y ₁	Relevance	0.876	42.211	Valid
Y ₂	Reliability	0.856	36.085	Valid
Y ₃	Comparability	0.817	18.447	Valid
Y ₄	Understandability	0.828	21.762	Valid

source: PLS Results

Based on table 4.4, it is known that the value of all factors exceeding 0.7 is included in the high category, meaning that all indicators used in the study have precisely measured the variables used in the study.

b. Discriminant Validity

To assess discriminant validity, Cross loading factor is used, which is a measure that shows the strength of the relationship of indicators with their latent variables. The following results show the cross loading factor for each variable used in the study.

Tabel 4.5
Cross Loading Factor

Indicators	Internal Control System	Accounting Information system	The Quality Of Government Financial Statement
X _{1.1}	0.834	0.402	0.494
X _{1.2}	0.981	0.585	0.723
X _{1.3}	0.977	0.584	0.734
X _{1.4}	0.990	0.563	0.713
X _{1.5}	0.976	0.605	0.695
X _{2.1}	0.754	0.765	0.602
X _{2.2}	0.497	0.845	0.563
X _{2.3}	0.289	0.813	0.427
X _{2.4}	0.368	0.792	0.480
X _{2.5}	0.454	0.809	0.601
X _{2.6}	0.239	0.753	0.468
Y _{.1}	0.727	0.637	0.876
Y _{.2}	0.638	0.660	0.856
Y _{.3}	0.502	0.448	0.817
Y _{.4}	0.494	0.527	0.828

source: PLS Result.

The cross loading factor results in table 4.5 show that the indicator correlation on the variable is higher than the indicator correlation with other variables, this shows that the indicators used have precisely measured the variables studied, in other words the indicator measurement model for the variable is acceptable.

c. Results of Goodness of Fit Test.

Fit test of combination models is a suitability test to validate the overall model, using the Goodness of Fit (GoF) value. The results of the evaluation of the fit test of combination model can be seen in table 4.6 as follows:

Tabel 4.6
GoF Result

Variabels	Communality	R Square
X ₁	0.909	0.619
X ₂	0.611	
Y	0.713	
means	0.744	0.619
multiplication	0.460	
GoF	0.678	

source: PLS Result.

Based on the table above, it is known that the Goodness of Fit (GoF) value of 0.460. GoF value of 0.678 according to Hair, et.al (2014) is classified as strong or high, so it can be concluded that the fitness test results of the goodness of fit model are classified as high.

1. Hasil Pengujian Inner Model (structural model)

After doing the inner model, then the outer model is tested or known as structural model measurement. in testing this structural model will be known to the influence between the variables studied. The hypothesis in this study will be tested using the path coefficient values and t-values presented as follows:

Tabel 4.
Nilai Koefisien Jalur Struktural dan Uji Signifikansi Hipotesis

Variables Interaction	Original Sample (O)	T Statistics (O/STERR)	T _{count}	T _{tabel}	Correlation	R ² (%)
The Influence of Internal Control (X ₁) to The Quality Of Government Financial Statement (Y)	0.476	6.141	6,141	1,677	0.713	33.94%
The Influence of Accounting Information System (X ₂) to theThe Quality Of Government Financial Statement (Y)	0.408	4.752	4,752	1,677	0.685	27.95%

source: PLS Result

Based on the table above, the structural path coefficient X₁ to Y is 0.476 and the structural path coefficient X₂ to Y is 0.408. Thus the structural equation model is obtained as follows:

$$Y = 0,476X_1 + 0,408X_2 + \zeta$$

Description

Y	=	The Quality Of Government Financial Statement
X ₁	=	Internal Control Systems
X ₂	=	Accounting Information System
ζ	=	Residual atau Error

Furthermore, the hypothesis testing results can be seen as follows:

- Based on the table above, the statistical value for the X₁ variable is 6.141. This value is greater than the t critical value of 1,677, so it can be concluded that H₀ is rejected and accepts H₁, meaning that the Internal Control System is proven to have a significant effect on the Quality of Regional Government Financial Statements at the Bandung Financial and Asset Management Agency with a contribution of 33.94%.
- Based on the table above, the statistical value for the X₂ variable is 4.752. This value is greater t critical value of 1,677, so it can be concluded that H₀ is rejected and accepts H₁, meaning that the Accounting Information System is proven to affect the Quality of Regional Government Financial Statements in the Financial and Asset Management Agency in Bandung with a contribution of 27.95%

Furthermore, we can be presented Full Model as follows:

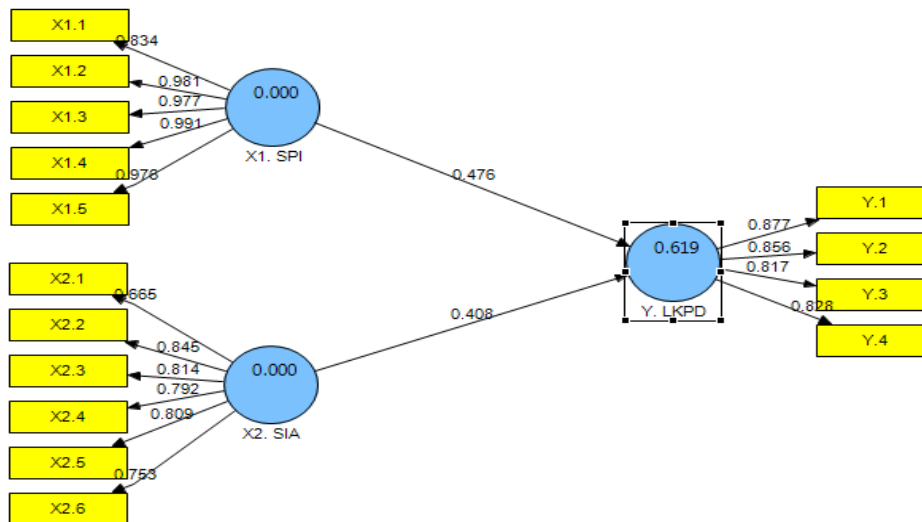

source: PLS Result

4.3. Discussion

4.3.1. The Effect of Internal Control Systems on the Quality of Regional Government Financial Statements

The internal control system has an effect on the quality of local government financial reports reaching 33.94%. The relationship of internal control systems to the quality of local government financial reports is positive, which means the better the internal control system that will make the quality of local government financial reports better. The results of this study are supported by the theory in the previous discussion, according to Nuramalia Hasanah and Achmad Fauzi (2016: 181) that the internal control system is an action and activity carried out by management (executive) and its staff, one of which is to provide adequate assurance or confidence in the quality of the report. local government finance.

This answers the phenomenon of the Internal Control System on the Quality of Regional Government Financial Statements that in a control environment where there is a lack of commitment to the placement of employees according to their competence. This fact is evidenced by the large number of government finance employees with non-accounting backgrounds, as a result various exercises lack maximum results. This is due to the determined employee selection model that is still general in nature and has not yet explored aspects of the examinees' accounting competencies so that the control environment is not good, causing the quality of local government reports to decline. This is in line with the results of research showing a positive relationship between the Internal Control System and the Quality of Local Government Financial Statements. this is evidenced by the indicator with the lowest score of the respondent's response is the environmental control indicator of 61.15% is categorized quite well, but there is still a gap of 38.85%. Where in the control environment there is still a lack of commitment to assigning employees according to their competencies. This was also supported by previous research, namely Teuku Fahrian Nagor (2015), Ida Ayu Enny Kiranayanti (2016), and Susilawati and Dwi Seftihani (2014).

4.3.2. The Effect of Accounting Information Systems on the Quality of Regional Government Financial Statements

Accounting information systems have an effect on the quality of local government financial statements of 27.95%. The relationship of accounting information systems to the quality of local government financial reports is positive, which means the better the accounting information system will make the quality of financial statements of local governments better. The results of this study are supported by the theory in the previous discussion, according to (Azhar Susanto, 2013: 37) that the main purpose of an accounting information system is to improve the quality of financial statements, namely information that is effective (complete), complete, reliable, and trusted (accurate) .

This answers the phenomenon of Accounting Information Systems on the Quality of Regional Government Financial Statements that in Brainware (Humans) where there is still a lack of competent human resources in the field of accounting. So that mistakes or errors are still found on the financial statements. This can be proven by the indicator that the lowest score of the respondent's response is an indicator of Brainware (Human) of 51.15% which is quite good, but there is still a gap of 48.84%.

This is also supported by previous research, namely Safrida Yuliani, et al (2010), Rukmi Juwita (2013), and Silviana (2013), the results of her research suggest that the Accounting Information System has a significant effect on the Quality of Regional Government Financial Statements.

V. CONCLUSIONS AND SUGGESTIONS

A. Conclusion

Based on the results of research and discussion that has been done about the influence of Internal Control Systems and Accounting Information Systems on the Quality of Local Government Financial Statements in the City of Bandung Financial and Asset Management Agency, at the end of this study, from this study where the authors can draw conclusions as following:

1. Internal Control System influences the Quality of Regional Government Financial Statements, where the better the Internal Control System will improve the Quality of Regional Government Financial Statements and vice versa.
2. Accounting Information Systems affect the Quality of Regional Government Financial Statements, where if the Accounting Information System is better, it will improve the Quality of Regional Government Financial Statements and vice versa.

B. Suggestions

Based on the conclusions above where the author can give the following advice:

1. The Internal Control System is proven to have an effect on the Quality of Regional Government Financial Statements, therefore to improve the Quality of Regional Government Financial Statements, the Internal Control System that needs to be given attention is on the environmental control indicators where the Regional Government must more often provide training and seminars to each of its employees, especially regarding the preparation of regional financial reports, besides that the Regional Government must be more selective in selecting its employees, the Regional Government must be able to ensure that employees who pass the recruitment selection have sufficient competence, so that the Regional Government can maintain the Quality of the Regional Government's Financial Statements.
2. Accounting Information Systems have proven to have an effect on the Quality of Regional Government Financial Statements, therefore to improve the Quality of Regional Government Financial Statements, the Accounting Information System that needs to be given focus is on Brainware (Human) indicators, where the Regional Government needs to evaluate whether its accounting staff are correct really understand accounting standards that are in line with local government or not, local governments must ensure that accounting staff are able to make reports in accordance with SAP in force to minimize errors in the preparation of financial reports and the quality of Regional Government Financial Reports can increase.
3. For the Development of Accounting, it is expected to be able to provide additional knowledge, as a source of information and as a contribution of thought in developing the public sector accounting discipline, as well as contributing to the development of research in particular regarding Internal Control Systems and Accounting Information Systems on the Quality of Regional Government Financial Statements.
4. For Researchers Furthermore, it is expected to be used as a reference so that in the future other researchers can use the same method with a record of variables, units of analysis, populations and different samples in order to obtain conclusions that support the theory and concept generally accepted

DAFTAR PUSTAKA

- Atyanto Mahatmyo. 2014. Sistem Informasi Akuntansi Suatu Pengantar. Yogyakarta: Deepublish.
- Azhar Susanto. 2013. Sistem Informasi Akuntansi. Bandung: Lingga Jaya.
- Baldric Siregar. 2017. Akuntansi Sektor Publik. Yogyakarta: Unit Penerbit dan Percetakan Sekolah Tinggi Ilmu Manajemen YKPN.
- Dadang Suwanda. 2017. Panduan Penerapan Reviu Laporan Keuangan Pemerintah Daerah. Bandung: PT Remaja Rosdakarya.
- Dwi Ratmono dan Mahfud Sholihin. 2015. Akuntansi Keuangan Daerah Berbasis Akrua. Yogyakarta: Unit Penerbit dan Percetakan Sekolah Tinggi Ilmu Manajemen YKPN.
- Hair, Joseph F., G. Thomas M. Hult., Christian M. Ringle., Marko Sarstedt. 2014. A Primer on Partial Least Squares Structural Equation Modeling (PLS-SEM). USA: Sage Publications, inc
- Ida Ayu Enny Kiranayanti. 2016. Pengaruh Sumber Daya Manusia, Sistem Pengendalian Intern, Pemahaman Basis Akrua terhadap Kualitas Laporan Keuangan Daerah. E-Jurnal Akuntansi Universitas Udayana. (Volume 16. 2 Agustus 2016; Hal. 1290-1318).
- Lilis Puspitawati & Sri Dewi Anggadini. 2011. Sistem Informasi Akuntansi. Yogyakarta: Graha Ilmu.
- Lilis Puspitawati & Sri Dewi Anggadini. 2019. The Influence of the Quality Accounting Information system to Quality of Accounting Information-Evidence in Indonesia. *Majalah Ilmiah Unikom*, Vol.17, No.1.
- Mahmudi. 2010. Manajemen Kinerja Sektor Publik. Yogyakarta: Unit Penerbit dan Percetakan Sekolah Tinggi Ilmu Manajemen YKPN.
- Mahmudi. 2016. Analisis Laporan Keuangan Pemerintah Daerah. Yogyakarta: Unit Penerbit dan Percetakan Sekolah Tinggi Ilmu Manajemen YKPN.
- Marakas, George M & James A. O'Brien. 2014. Introduction to information System. Sixteenth Edition. Boston: McGraw-Hill.Inc.
- Marshall B. Romney dan Steinbart, Paul John. 2009. Accounting Information Systems. USA: Cengage Learning.
- Marshall B. Romney dan Steinbart, Paul John. 2015. Sistem Informasi Akuntansi. Jakarta: Salemba Empat.
- Moh Mahsun. 2016. Akuntansi Sektor Publik. Yogyakarta: BPFE.
- Nuramalia Hasanah dan Achmad Fauzi. 2016. Akuntansi Pemerintahan. Jakarta: In Media.
- Puspitawati, L., Susanto, A., Poulus, S., Suprijadi, J. (2018). The critical success factors of the business strategy in the effectiveness of Management Accounting Information System evidence in Indonesia. *Journal of Engineering and Applied Sciences*. Vol.13.No.15. 2018
- Rizki Ahmad Fauzi. 2017. Sistem Informasi Akuntansi (Berbasis Akuntansi). Yogyakarta: Deepublish.

- Rukmi Juwita. 2013. Pengaruh Implementasi Standar Akuntansi Pemerintahan dan Sistem Informasi Akuntansi terhadap Kualitas Laporan Keuangan. *Jurnal Trikomonika*. (Volume 12, No. 2, Desember 2013; Hal. 201–214).
- Safrida Yuliani, Nadirsyah dan Bakar, Usman. 2010. Pengaruh Pemahaman Akuntansi, Pemanfaatan Sistem Informasi Akuntansi Keuangan Daerah dan Peran Internal Audit terhadap Kualitas Laporan Keuangan Pemerintah Daerah. *JURNAL TELAHAH & RISET AKUNTANSI*. (Vol. 3. No. 2. Juli 2010; Hal. 206-220).
- Silviana. 2013. Hubungan Penerapan Sistem Informasi Akuntansi terhadap Kualitas Laporan Keuangan Pemerintah Daerah. *Proceeding Call for Papers dan Seminar Nasional Fakultas Ekonomi UNS*. (30-31 Mei 2013).
- Susilawati dan Dwi Seftihani Riana. 2014. Standar Akuntansi Pemerintahan dan Sistem pengendalian Intern sebagai Antecedent Kualitas Laporan Keuangan Pemerintah Daerah. *Star-Study & Accounting Research*. (Volume XI, No. 1, 2014; Hal. 15-32).
- Teuku Fahrian Nangor, Darwanis, dan Abdullah, Syukriy. 2015. Pengaruh Penerapan Sistem Pengendalian intern dan Penerapan Prinsip Pengelolaan Keuangan Daerah terhadap Kualitas Laporan Keuangan Pemerintah Daerah Kabupaten Aceh Barat: Studi pada SKPD Pemerintah Daerah Kabupaten Aceh Barat. *Jurnal Magister Akuntansi Pascasarjana Universitas Syiah Kuala*. (Volume 4, No. 1, Februari 2015; Hal. 72- 79).