

Implementation of Critical Path Method in Project Planning and Scheduling

by Sufa atin

Submission date: 04-Mar-2024 01:14PM (UTC+0700)

Submission ID: 2311103850

File name: artikel_B.A.19.pdf (907.17K)

Word count: 2604

Character count: 12039

PAPER · OPEN ACCESS

2

Implementation of Critical Path Method in Project Planning and Scheduling

7

To cite this article: S Atin and R Lubis 2019 *IOP Conf. Ser.: Mater. Sci. Eng.* **662** 022031

View the [article online](#) for updates and enhancements.

You may also like

- [A rescheduling approach based on genetic algorithm for flexible scheduling problem subject to machine breakdown](#)
Li Nie, Xiaogang Wang, Kai Liu et al.
- [4 Comprehensive Survey on Load and Resources Management Techniques in the Homogeneous and Heterogeneous Cloud Environment](#)
Ramanpreet Kaur, Sahil Verma, Kavita et al.
- [4 Priority Intensed Meta Task Scheduling Algorithm for Multi Cloud Environment \(PIMTSA\)](#)
BJ. Hubert Shanthan, L. Arockiam, A. Cecil Donald et al.

PRIME
PACIFIC RIM MEETING
ON ELECTROCHEMICAL
AND SOLID STATE SCIENCE

HONOLULU, HI
Oct 6–11, 2024

Abstract submission deadline:
April 12, 2024

Learn more and submit!

Joint Meeting of
The Electrochemical Society
•
The Electrochemical Society of Japan
•
Korea Electrochemical Society

2

Implementation of Critical Path Method in Project Planning and Scheduling

S Atin^{1*}, R Lubis¹

¹Informatics Engineering , Faculty Of Engineering and Computer Science,
Universitas Komputer Indonesia, Indonesia.

Email: sufaatin@email.unikom.ac.id

Abstract. Scheduling in a project is a tool to determine the activities needed to complete a project in a certain order and time frame, in which every activity must be carried out so that the project is completed on time at an economical cost. The purpose of this study is to find out the critical path in project implementation and find out which projects are postponed and which cannot be delayed in their completion which can affect the entire project work process so that the project can be completed on time. The method used in this study is the Critical Path Method (CPM), which is a network method that has a series of activity components with the longest total amount of time and shows the fastest time period of completion. The results of this study indicate that the use of CPMs is able to get the longest total amount of time with the fastest project completion period, project scheduling and project critical paths can be seen more clearly so that the project can be completed on time.

5

1. Introduction

The project is a combination of several resources (labor, budget, equipment, facilities, support services) in one organization to achieve the stated objectives [1]. Planning is an activity carried out in the project to anticipate existing tasks and conditions by setting goals and objectives to be achieved and determining implementing policies, programs to be carried out, schedule and time of implementation, implementation procedures and administrative and operational as well as budget and source power [2]. Project scheduling is an activity carried out to determine the duration of project activities that must be completed, raw materials, labor and the time needed by each activity [2]. To make planning and scheduling projects can use several methods, one of which is the Critical Path Method (CPM) [3]. CPM is an integrated network consisting of a series of activities with one another intended to obtain maximum work efficiency [3]. In determining the total time, the CPM project is simpler, it is obtained by summing the duration of each activity and taking the last / greatest finish time. The path where delays may not occur in each project activity is called the critical path [3]. CPM is more used than other traditional methods. CPM concentrates on the most important tasks the project can be confirmed on time and in line with the predetermined schedule [4][5].

Some previous studies using CPM were studies carried out by the 1950 DuPont Company and Remington Rand Corporation, CPMs used to manage power plants and construction could save the company one million dollars in the first year of use [5]. In 2013 Putra proved that scheduling time using CPM proved to be very helpful in time and cost efficiency [6]. Another study conducted by Hamzah et al. In 2013 [7] proved that CPM networks help in time and cost efficiency. As well as a study conducted by Ezekiel, et al. [8] stated that CPM is suitable for scheduling, formulating, and managing various



activities in all construction work, because it provides a schedule built on experience, and observations that have been made.

The purpose of this study is to find a project critical path that can be used to find out the longest time the project is completed, as well as the project leader's guidance to determine which jobs can be delayed and which jobs cannot be delayed. In this study, researchers used CPM to design and schedule projects so that a critical path in construction projects was obtained, namely the construction of government buildings. By using the CPM time of project execution and the critical path of the project can be known so that the project can be completed on time.

2. Methodology

The research methodology used in this research is descriptive methodology. Descriptive methodology is a research methodology that is used to make descriptions, drawings or paintings systematically, factually and actually about the facts, the characteristics and relationships between the phenomena investigated. The methodology of this research begins with a review of CPM literature studies together with secondary data collection and determining the logical relationship between jobs. Then calculate the project's forward time value, then calculate the project backward time. After the forward time and backward time, the next step is to calculate the total float and determine the critical path and the last one produces the design guide and project scheduling.

3. Results and Discussion

3.1. Secondary Data Collection

The data used in this study is a data on the construction of BUMN buildings in the city of Bali, where the project implementation schedule starts from January 9, 2017 to December 18, 2017 (350 days or 50 weeks). There are five steps to using CPM [9], namely identifying all project activities, calculating forward time, calculating backward time, calculating float and building a network diagram. The identification, activities, relationships between jobs and duration of project work can be seen in Table 1.

Table 1. Activity, relationship between work and duration of project work

No.	Job Name	Code	Prior Job	Follower's work	Duration (weeks)
I	Project Preparation Work	I	Start	II, III	4
II	Site Development Job	II	I	V	22
III	Lower Building Works	III	I	IV, VII	14
IV	Upper Building Works	IV	III	VI	12
V	Roof and Canopy Jobs	V	II	IX	8
VI	Install Work and Partitions	VI	IV	VIII	2
VII	Floor and Wall Coating Work	VII	III	IX	16
VIII	Doors, Windows and Locking Works	VIII	VI	X	4
IX	Ladder Railing Work	IX	V, VII	XI, XV	4
X	Roof and Ceiling Jobs	X	VIII	XII, XVII	4
XI	Painting Work	XI	IX	XIII, XVI	4
XII	Interior work	XII	X	XIV	4
XIII	Furniture work	XIII	XI	XVIII	4
XIV	Main Building-Electric Work	XIV	XII	End	4
XV	Electrical Site Development and Guard Posts	XV	IX	XVIII	8
XVI	Electronic work	XVI	XI	XVIII	4
XVII	Plumbing work	XVII	X	End	8
XVIII	Drainage Work	XVIII	XIII, XV, XVI	End	2

3.2 Calculating Forward Time

The first step to find a critical path is to calculate the forward time, namely the fastest time of a project can be completed using the formula $EF(i-j) = ES(i-j) + D(i-j)$ [10], then the forward time value is obtained as in Table 2.

Table 2. Forward time calculation results

Activities			Dution	Forward Calculation	
I	J	Code		ES	EF
0	1	I	4	0	4
1	2	II	22	4	26
1	3	III	14	4	18
3	4	IV	12	18	30
2	5	V	8	26	34
4	6	VI	2	30	32
7	9	VII	16	18	34
6	8	VIII	4	32	36
5	9	IX	4	34	38
8	10	X	4	36	40
9	11	XI	4	38	42
10	12	XII	4	40	44
11	18	XIII	4	42	46
14	19	XIV	4	44	48
9	18	XV	8	38	46
11	18	XVI	4	42	46
10	19	XVII	8	40	48
18	19	XVIII	2	46	48

3.3 Calculating Countdown Time

After calculating the forward time, the next step is to calculate the countdown time, the countdown time is done starting at the end of the moving network towards the beginning of the network [11]. Calculation of backward time is used to find the longest time of a project can be solved using the formula $LS(i-j) = EF(j-i) - D(i-j)$ and the countdown time is obtained as in table 3.

Table 3. Countdown time calculation results

Activities			Duration	Countdown Calculation	
I	J	Code		LS	LF
0	1	I	4	0	4
1	2	II	22	4	26
1	3	III	14	4	18
3	4	IV	12	18	30
2	5	V	8	26	34
4	6	VI	2	30	32
7	9	VII	16	22	38
6	8	VIII	4	32	36
5	9	IX	4	34	38
8	10	X	4	36	40
9	11	XI	4	38	42
10	12	XII	4	40	44
11	18	XIII	4	42	46
14	19	XIV	4	44	48
9	18	XV	8	38	46
11	18	XVI	4	42	46
10	19	XVII	8	40	48
18	19	XVIII	2	46	48

3.4 Calculating Total Float

Total float is the amount of time allowed for an activity to be delayed, without knowing the overall project schedule. To calculate the total float in this study using the formula $TF = LS - ES$. The results of the total float calculation can be seen in Table 4.

Table 4. Total float calculation results

	Activities			Duration	Forward Calculation		Countdown Calculation		TF
	I	J	Code		ES	EF	LS	LF	
0	1	I	4	0	4	0	4	0	
1	2	II	22	4	26	4	26	0	
1	3	III	14	4	18	4	18	0	
3	4	IV	12	18	30	18	30	0	
2	5	V	8	26	34	26	34	0	
4	6	VI	2	30	32	30	32	0	
7	9	VII	16	18	34	22	38	4	
6	8	VIII	4	32	36	32	36	0	
5	9	IX	4	34	38	34	38	0	
8	10	X	4	36	40	36	40	0	
9	11	XI	4	38	42	38	42	0	
10	12	XII	4	40	44	40	44	0	
11	18	XIII	4	42	46	42	46	0	
14	19	XIV	4	44	48	44	48	0	
9	18	XV	8	38	46	38	46	0	
11	18	XVI	4	42	46	42	46	0	
10	19	XVII	8	40	48	40	48	0	
18	19	XVIII	2	46	48	46	48	0	

Based on the calculations in table 4, it can be concluded that the initial total project work is 48 weeks, and the work in the critical path can be determined by looking at the results of Total Float (TF), $TF = 0$, from the results the critical path is obtained at work I- II-V-IX-XV-XVIII. The results of analysis of project critical work can be seen in table 5 while the project network can be seen in Figure 1.

Table 5. Project Critical Job Analysis Results

No	Jobs Name	Code	Duration (Weeks)	Jobs Status
I	Project Preparation Work	I	4	Critical path
II	Site Development Job	II	22	Critical path
III	Lower Building Works	III	14	-
IV	Upper Building Works	IV	12	-
V	Roof and Canopy Jobs	V	8	Critical path
VI	Install Work and Partitions	VI	2	-
VII	Floor and Wall Coating Work	VII	16	-
VIII	Doors, Windows and Locking Works	VIII	4	-
IX	Ladder Railing Work	IX	4	Critical path
X	Roof and Ceiling Jobs	X	4	-
XI	Painting Work	XI	4	-
XII	Interior work	XII	4	-
XIII	Furniture work	XIII	4	-
XIV	Main Building-Electric Work	XIV	4	-
XV	Electrical Site Development and Guard Posts	XV	8	Critical path
XVI	Electronic work	XVI	4	-
XVII	Plumbing work	XVII	8	-
XVIII	Drainage Work	XVIII	2	Critical path

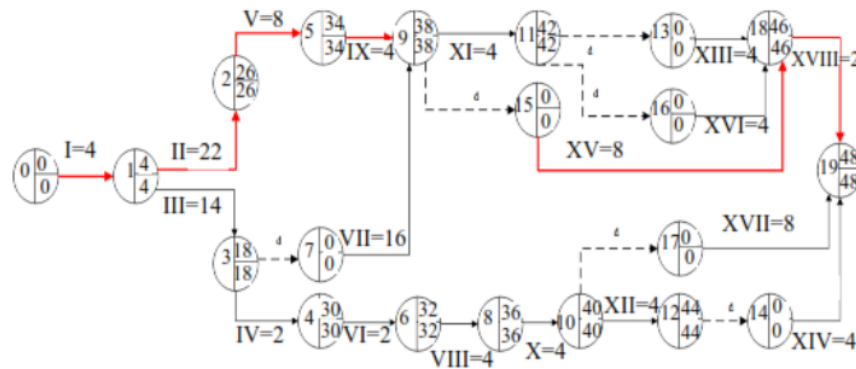

Figure 1. Project Work Network

3.5 Results and Differences with Previous Research

Based on the calculations made, the results show that a CPM can save project time and produce a critical path that can be used as a guide for project implementation so that the project can be completed on time, this result is in line with the research conducted by Putra and Hamzah. In addition, CPM can help in the time efficiency and cost of the project differently from the research developed by DuPont Company and Remington Rand Corporation which CPM can only save on project costs.

4. Conclusion

The conclusion in this study is that the critical path on the project can be used to determine the longest time that shows the project completion period. In addition, the critical path can be a reference for project leaders in the project that work on the critical path must be timely in order for the project to finished on time.

5. Acknowledgments

The researcher thanked to The Directorate of Research and Community Service Institution (LPPM) Universitas Komputer Indonesia for funding this research using the internal research scheme in 2018, and the xyz company for data contributions for this study.

References

[1] Atin, S., Harihayati, T. and Widiyanti, U.D., 2018, August. "Utilization of function point method for measuring software project complexity". In *IOP Conference Series: Materials Science and Engineering* (Vol. 407, No. 1, p. 012086). IOP Publishing.

[2] Heryanto. I, Triwibowo.T, (2016) "Manajemen Proyek Berbasis Teknologi Informasi", Informatika Bandung, Revisi Kedua.

[3] John. M. Nocolas, 2004, "Project management for Business and Engineering": Principles and Parctice 2nd ed. Burlington : Elsevier Inc, 2004.

[4] James E. Kelley, Jr.F And Margon R. Walker.1959, "Critical Path Planning And Scheduling", Proceedings Of the Eastern Joint Computer Conference.

[5] Rogelio, A., Spring 2010, "Analysis Of Project Planning Using CPM And Pert", In Pathial Fulfillment Of Math 4395-Senior Project, Department Of Computer And Mathematical Science.

- [6] Putra, A.E., 2013, "Analisis Pengendalian Waktu Dan Biaya Dengan Metode Crash Program (Studi Kasus: Pembangunan Bali Adat Belalawan, Tesis Fakultas Teknik Sipil, Program Magister Teknik Sipil Universitas Islam Indonesia.
- [7] Sugiyarto, Qomariyah. S., Hamzah. F., 2013, " Analisis Network Planning dengan CPM (Critical Path Method) Dalam Rangka Efisiensi Waktu dan Biaya Proyek", ISSN 2354-8630, e-Jurnal Matriks Teknik Sipil Vol.1 no.4/Desember 2013/408
- [8] Ezekiel R. M. Iwawo, Jermias Tjakra, & Pingkan A.K. Pratisis, 2016, Penerapan Metode CPM Pada Proyek Konstruksi (Studi Kasus Pembangunan Gedung Baru Kompleks Eben Haezer Manado). Jurnal Sipil Statistik, 4 (9) : 551-558.
- [9] Holliday, I., 2002, Building E-Government In East And Southeast Asia: Regional Rhetoric And National (in) Action. Public Administration & Development, 22 (4), 323-335.
- [10] Hartono. I., 1995, Manajemen Proyek : Dari Konseptual Sampai Operasional
- [11] Taylor. B. W., 2011. Introduction To Management Science.

Implementation of Critical Path Method in Project Planning and Scheduling

ORIGINALITY REPORT

16%

SIMILARITY INDEX

11%

INTERNET SOURCES

16%

PUBLICATIONS

%

STUDENT PAPERS

PRIMARY SOURCES

1	www.coursehero.com Internet Source	4%
2	iopscience.iop.org Internet Source	2%
3	lib.unnes.ac.id Internet Source	2%
4	Xin Wang. "An Energy Efficiency Optimization Method Based on Decoupling in Cloud Computing", IOP Conference Series: Materials Science and Engineering, 2019 Publication	2%
5	S Atin, T Harihayati, U D Widianti. "Utilization of function point method for measuring software project complexity", IOP Conference Series: Materials Science and Engineering, 2018 Publication	2%
6	www.seminarpasca-sttal.ac.id Internet Source	2%

7

I Afrianto, R G Guntara. "Implementation of User Centered Design Method in Designing Android-based Journal Reminder Application", IOP Conference Series: Materials Science and Engineering, 2019

Publication

2%

Exclude quotes On

Exclude matches < 2%

Exclude bibliography On